

“Towards an Earth-Moon Economy – Developing Off-Planet Resources”

# Moon Miners’ Manifesto

India Quarterly Edition

[www.moonsociety.org/india/mmm-india/](http://www.moonsociety.org/india/mmm-india/)

#11

JUL-SEP 2011



*JAXA (Japan) human-robotic moonbase concept*

## Feature Articles This Issue

- p. 17 Human Space Activity: The Spiritual Experience  
By Madhu Thangavelu
- p. 20 The Case for Going to the Moon  
Review and Commentary by David Dunlop
- p. 22 A Global View of Space Settlement Policy,  
By David Dunlop
- p. 25 Mapping the Era of Lunar Exploration,  
By David Dunlop
- p. 30 Exploring the Many Possibilities of Hybrid  
Rigid-Inflatable Architectures  
By Peter Kokh
- p. 34 Redhousing: Breeding “Mars-Hardy” Plants,  
By Peter Kokh

Complete article & feature index *on the last page*

## It is reasonable to ask if we are not too narrowly focused on the Moon

In fact it was the groundswell of public enthusiasm in India upon the successful launch of Chandrayaan-1 to the Moon that encouraged us to launch M3IQ. But *the Moon Society is also very interested in Mars, and the Asteroids and in space in general and we collaborate with many other organizations*. The Moon Society is mutually affiliated with the National Space Society. We have also collaborated with The Mars Society in research at the Mars Desert Research Station, and work productively with MarsDrive, Mars Foundation, and ExploreMars.org as well as with OpenLuna.org.

In M3IQ #1, our very first issue, in the article “**Triway to Space**” pages 13-14, we explained that the root motivations behind those who focus on the Moon, on Mars, and on the Asteroids is one and the same: **Earth’s Survival**. *We can and must respect and work with one another!* **PK**

## About The Moon Society

<http://www.moonsociety.org>

### Our Vision says Who We Are

We envision a future in which the free enterprise human economy has expanded to include settlements on the Moon and elsewhere, contributing products and services that will foster a better life for all humanity on Earth and beyond, inspiring our youth, and fostering hope in an open-ended positive future for humankind.

### Moon Society Mission

Our Mission is to inspire and involve people everywhere, and from all walks of life, in the effort to create an expanded Earth-Moon economy that will contribute solutions to the major problems that continue to challenge our home world.

### Moon Society Strategy

We seek to address these goals through education, outreach to people of all ages, through contests & competitions, workshops, ground level research and technology experiments, private entrepreneurial ventures, analog research and other means. *We collaborate with Mars-focused and other organizations.*

## About Moon Miners' Manifesto

<http://www.MoonMinersManifesto.com>

MMM is published 10 times a year (except January and July. The December 2009 issue began its 24<sup>th</sup> year of continuous publication.

Most issues deal with the **opening of the Lunar frontier**, suggesting how pioneers can make best use of **local resources** and learn to **make themselves at home**. This will involve psychological, social, and physiological adjustment.

Some of the points made will relate specifically to **pioneer life** in the lunar environment. But much of what will hold for the **Moon**, will also hold true for **Mars** and for space in general. We have one Mars theme issue each year, and occasionally **other space destinations** are discussed: the asteroids, Europa (Jupiter), Titan (Saturn), even the cloud tops of Venus.

Issues #145 (May 2001) forward through current are as pdf file downloads with a Moon Society username and password. Moon Society International memberships are \$35 US; \$20 students, seniors – join online at:

<http://www.moonsociety.org/register/>

**MMM Classics:** All the “non-time-sensitive editorials and articles from past issues of MMM have been re-edited and republished in pdf files, one per publication year. A 3-year plus lag is kept between the MMM Classic volumes and the current issue. These issues are freely accessible, no username or password needed, at:

[www.moonsociety.org/publications/mmm\\_classics/](http://www.moonsociety.org/publications/mmm_classics/)

### Editors of MMM-India Quarterly:

**Peter Kokh** [kokhmmm@aol.com](mailto:kokhmmm@aol.com)

**Madhu Thangavelu** [thangavelu-girardey@cox.net](mailto:thangavelu-girardey@cox.net)

**David A. Dunlop** [dunlop712@yahoo.com](mailto:dunlop712@yahoo.com)

**Pradeep Mohandas** [pradeep.mohandas@gmail.com](mailto:pradeep.mohandas@gmail.com)

**Srivas Laxman** [moonmission.srinivas@gmail.com](mailto:moonmission.srinivas@gmail.com)

## About MMM-India Quarterly

<http://www.moonsociety.org/india/mmm-india/>

This publication was launched with the Fall 2008 issue. This issue completes our 2<sup>nd</sup> year. The Moon Society was founded as an International organization, but in fact has few members outside the United States, and these are for the most part solitary and unorganized.

### Background

The Moon Society and The Planetary Society of Youth (TPSY) in India, <http://www.youthplanetary.org/> in December 2003, put together a "Design a Mission to the Moon" category in TPSY's student design contest -- "A Mission to the Moon and Beyond."

The contest was designed to help students learn about various objects in the solar system as they compete in the design of a mission.

[www.youthplanetary.org/moon\\_mission\\_contest.html](http://www.youthplanetary.org/moon_mission_contest.html)

### Why an MMM-India Quarterly?

India is a very populous country, and one in which, through the heritage of the British Raj, English is the almost universal medium of higher education. It is likely that English-fluent Indians outnumber English speakers in the United States. More books are published in English than in any other country.

*And – India has now gone to the Moon!*

In short, we want to share with space-interested and space-enthused people in India, our vision of the possibilities for Exploration and Utilization of the Moon, development of lunar resources, not just to support a permanent population on the Moon, but to help better address chronic clean energy supply problems on Earth and to help slow and reverse our home planet's environmental degradation in the process. In short, we would like to share our glimpse of an emerging greater Earth-Moon Economy.

This vision was well-expressed by the former President of India, Dr. A. P. J. Abdul Kalam in a speech at The Symposium on “The Future of Space Exploration: Solutions to Earthly Problems” to mark the occasion of the 50th Anniversary of the dawn of Space Age, Boston University, Boston, MA, April 12, 2007.

In this speech, Dr. Kalam made the point that to fully industrialize and become an equal partner in the future of our planet, India needs to access the unlimited clean undiluted solar energy available in space. We agree with his assertions and want to share that bold vision with the forward-looking people of India.

### Free Access:

MMM-India Quarterly issues are available as a free access pdf file, downloadable from this address:

<http://www.moonsociety.org/india/mmm-india/>

We encourage readers to share these files with others freely, and to use this publication to grow and cultivate wide-spread interest in the open-ended possibilities of space among the people of India, and to encourage the rise of additional citizen support space organizations within the country.



# Indian Space News

## Chandrayaan-2 Faces Delay

[http://www.daijiworld.com/news/news\\_disp.asp?n\\_id=104621&n\\_tit=Chandrayaan-2+Faces+Delay](http://www.daijiworld.com/news/news_disp.asp?n_id=104621&n_tit=Chandrayaan-2+Faces+Delay)

7 June 2011 – Realising that the advanced GSLV MK-III won't be available by 2014, ISRO is revisiting its plans for the launch of the ambitious joint Indian-Russian Chandriyaan-2/lunar-resurs lunar lander. Plan B is to launch the mission using GSLV F-series once it clears its next mission. But this will require some adjustments.

“Chandrayaan-2 has been designed to go on GSLV MK-III,” a top source told Deccan Chronicle. “But the development process has run up to a brick wall following back-to-back launch failures. The moon mission is already delayed. A decision to launch it with base model of GSLV has been taken.”

The Chandrayaan-2 team has been asked to tweak the programme wherever possible as GSLV can launch only lesser tonnage than the advanced MK-III version. “This will delay the project by at least six months,” said the source.

### More Information on Chandrayaan-2 in M3IQ:

- M3IQ featured articles on Chandrayaan-2 lander/rovers
- in issue # 2 page 4 “Chandrayaan-2 Looking Forward”
- issue # 8 page 3 “Chanrayaan-2 Report” by Srivinas Laxman; and on page 5 “Chandrayaan-2 Payloads” by Pradeep Mohandas;
- in issue #9 page 3 ”Sites picked for Chadrayaan-2 lander mission”

### Other sources:

<http://en.wikipedia.org/wiki/Chandrayaan-2>

## GSLV Investigation - Chandrayaan-2 Downscope - Antrix Reform

<http://www.parabolicarc.com/2011/06/08/isro-update-gslv-investigation-chandrayaan2-downscope-antrix-reform/>

### GSLV Investigation

ISRO has traced the loss of GSLV-F06 to a **failure of the composite shroud on the vehicle’s Russian cryogenic engine**. “The problem with GSLV is of a minor nature and it **does not call for major changes**,” Nair says. Discussions have begun with Russia ong the shroud issue.

### GLSV Mark III

Development of the uprated GLSV Mark III rocket is falling behind schedule, which will have an impact on India’s Chandrayaan-2 lunar mission:

### Antrix Reform

The controversial Antrix-Devas deal has not impacted the Indian Space Research Organisation (ISRO) as the space agency’s commercial arm is still receiving enquiries from various countries for launching satellites and building satellites. ▣

## Astronomy Images from India’s 2m Himalayan Chandra Telescope

The website for this telescope located high in the Himalayan Mountains provides some remarkable space photos. There are several pictures of Super Novas and many other amazing images from space at:

[http://www.iiap.res.in/iao/astro\\_gallery.html](http://www.iiap.res.in/iao/astro_gallery.html)

Courtesy of the Indian Astronomical Observatory, Indian Institute of Astrophysics.



BVR composite image of the Open Cluster NGC 6819

Can you imagine what Earth’s nighttime skies would look like if our Sun were located in the middle of such a cluster? Would this have advanced the pace of our scientific and technological development? Would we be more eager to leap beyond our sister planets to such a feast of nearby star systems? How different would human history have been? What influence might such a situation have had on our religions and philosophies? We can only wonder, and be thankful that our interstellar neighborhood is not near a recent major supernova that could have wiped out life on Earth. Maybe being in a nondescript interstellar neighborhood is a good thing! The sight of Earth’s heavens has always been inspiring to me, but we can wonder.- P. Kokh

### Some other photos from the Observatory:





# Elsewhere in Asia

## Chinese National Space Agency



### China to make 1<sup>st</sup> Docking Procedure

<http://www.physorg.com/news/2011-04-china-space-rendezvous.html>

29 April 2011 - **China will attempt its first space docking between two unmanned vehicles this year, the first step in efforts to build a Chinese space station**

Yang Liwei, China's first man in space, reports that CSNA plans to attempt a "space docking" of two vehicles during the second half of 2011. This manoeuvre will involve the **Tiangong 1 module** and the **Shenzhou 8 capsule**. This first feat will be unmanned. As a follow-on, both the **Shenzhou 9 and 10 capsules**, both with astronauts on board will practice docking..

The purpose of these increasingly more bold steps is to gain the confidence and experience that will be needed to build and deploy China's first manned space station by 2020. This station will be made up of a core module, two laboratories, a cargo ship and a manned vehicle, with a total weight of 60 tonnes, compared with 137 tonnes for the Russian station Mir and 419 tonnes for the International Space Station (ISS)

Several nations and space agencies involved in ISS would like to see China (and India, for that matter) participate in the ISS program. ISS' lifetime has been extended to 2020, but it is likely that further extensions of this successful program will be made. ▣

### China's 2nd moon orbiter Chang'e-2 heads for Outer Space

[www.thaindian.com/newsportal/sci-tech/chinas-second-moon-orbiter-change-2-heads-for-outer-space\\_100542053.html](http://www.thaindian.com/newsportal/sci-tech/chinas-second-moon-orbiter-change-2-heads-for-outer-space_100542053.html)

9 June 2011 - On this day, China's 2<sup>nd</sup> Moon Orbiter Chang'e-2, after a successful 1-year mission in orbit around the Moon, but still fully functional and fuel still in its tank, left lunar orbit for "deep space" on an 85 day mission to give mission controllers experience with probes venturing further into space. CSNA claims this as a first, but **Clementine** attempted such an aftermission in 1994 but soon went radio-silent, thus effectively "lost."

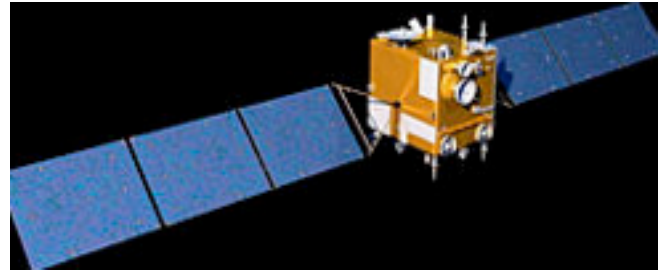

Illustration of Chang'e-2

### China to send Robot to the Moon in 2013?

<http://spectrum.ieee.org/automaton/aerospace/robotic-exploration/how-china-plans-to-send-robots-to-the-moon>



No spacecraft, American, Russian, or from any other country or space agency has soft-landed on the Moon since 1976 – 35 years! That means that all lunar science in the interim has been done from orbit, or in laboratories on Earth with samples of lunar material retrieved decades ago. The need for more lunar surface science is enormous and continues to increase as science done from orbit illuminate ever more areas of real "ignorance."

But hopefully that will change with Chandrayaan-2/Lunar Resurs lander and rover, the Chang'e-3 lander, and hopefully some successful Google Lunar –Prize efforts.

The above illustration looks very much like that of Curiosity, NASA's planned successor to its successful Spirit and Opportunity probes, including the advanced 6-wheel 2-axel chassis developed after much trial and error with other types of suspension. Curiosity, however, is bound for Mars.

"Chang'e-3 is scheduled to land in Sinus Iridium sometime 'around 2013.' This will be the mission with an unmanned lunar lander and a 120-kilogram autonomous lunar rover, able to choose its own routes, avoid obstacles, and perform science experiments with a suite of sensors, including cameras, x-ray and infrared spectrometers, and a ground-penetrating radar." ▣



**Japan  
Aerospace  
Exploration  
Agency**



**Ikaros Solar Sail Update**

[http://www.aviationweek.com/aw/generic/story\\_channel.jsp?channel=space&id=news/asd/2011/06/02/11.xml&headline=Japanese Researchers Controlled Solar Sail](http://www.aviationweek.com/aw/generic/story_channel.jsp?channel=space&id=news/asd/2011/06/02/11.xml&headline=Japanese%20Researchers%20Controlled%20Solar%20Sail)

The **Ikaros solar sail** launched with Akatsuki 20 May 2010 has been a successful technology demonstrations.

**Researchers have successfully demonstrated**

- automatic sail deployment
- **power generation with thin-film solar cells** on the sail surface
- **verification that the pressure of photons from the Sun caused the sail to accelerate**, and
- **guidance and navigation with the sail.**

The sail met its intended acceleration of **100 m per second** and veered off the ballistic trajectory it would have followed without the Sun's pressure.

**A challenge met deserves one more ambitious encore**

JAXA researchers are now designing a solar sail with ten times the surface area (each side 3.16 times the length of Aatsuki's sail. This second iteration will be for a 5-year mission, ten times as long as Ikaros' 6-month effort. SeeM3IQ#9, page 6, "**Japan plans ambitious 2<sup>nd</sup> solar sail mission**" to Jupiter and its Trojan asteroids never before visited, as far from Jupiter as Jupiter is from the Sun.

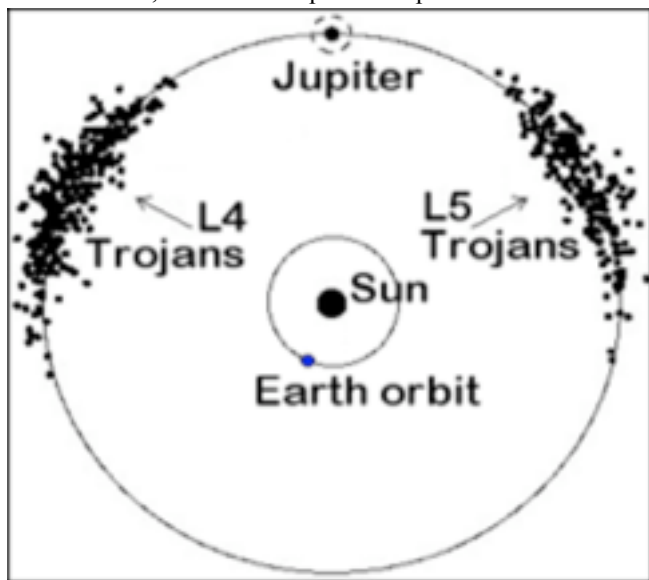

**Why Akatsuki failed to orbit Venus**

<http://planetary.org/blog/article/00003085/>

June 30, 2011 - A clogged valve in a pipe linked to a fuel tank caused the failure of the Akatsuki probe to enter orbit around Venus. The valve clogged up, resulting in an insufficient fuel supply to the engine. Oxidizer that boosts fuel combustion ran back and came into contact with fuel, causing crystals to form, clogging the valve. □

**Russian  
Space  
Agency**



**Coming! An all new Soyuz Capsule**

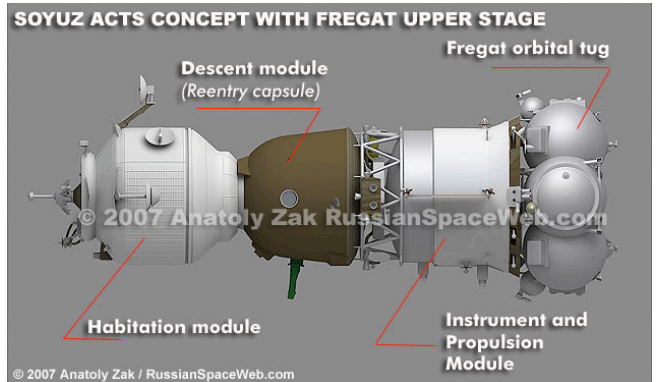

[http://en.wikipedia.org/wiki/Soyuz\\_\(spacecraft\)#Soyuz ACTS\\_282012.2F....29](http://en.wikipedia.org/wiki/Soyuz_(spacecraft)#Soyuz ACTS_282012.2F....29)

**Soyuz ACTS (2012/....)**

**Soyuz ACTS (Advanced Crew Transportation System)**, also known as **Soyuz-K**, is a proposed version of the Soyuz design capable of achieving **lunar orbit**. The upgrades could include a **new habitation module** developed by the European Space Agency. A novel, rocket-based precision landing system may also be implemented.[8] Missions could be launched from Baikonur or Guiana Space Centre.[

The "pre-history" of this vehicle goes way back to the 1960s when this version was developed to carry then Soviet cosmonauts to the Moon, during the space race between the USA and the USSR, won by Apollo 11.

For more:

[http://www.thefullwiki.org/Soyuz\\_7K-L3](http://www.thefullwiki.org/Soyuz_7K-L3) □

**The Future of Baikonur Cosmodrome**

26 April 2011 – Russia and Kazakhstan begin joint talks on future of Baikonur Cosmodrome as a jointly owned facility.

[www.spacedaily.com/reports/Kazakhstan\\_Open\\_To\\_Discuss Turning Baikonur Space Center Into JSC 999.html](http://www.spacedaily.com/reports/Kazakhstan_Open_To_Discuss_Turning_Baikonur_Space_Center_Into_JSC_999.html)

Russia has proposed converting the Baikonur Space Center into a joint-stock company with Russia as a major shareholder. Baikonur is located in Kazakhstan and leased by Russia until 2050. Russia plans to cut the share of its space flights from Baikonur to only 11 percent as soon as its **Vostochny** space launch facility in the Amur region of Siberia (51°49'N 128°15'E) starts operation in 2015.

**For more** on the Vostochny Cosmodrome:

[http://en.wikipedia.org/wiki/Vostochny\\_Cosmodrome](http://en.wikipedia.org/wiki/Vostochny_Cosmodrome) □

## TURKMENISTAN

*Map of Turkmenistan and place in Asia*

### 31 May 2011 - Turkmenistan launches its own national Space Agency

[http://sarkaritel.powweb.com/news\\_and\\_features/may2011/31turkmenistan\\_sets\\_up\\_space\\_agency.htm](http://sarkaritel.powweb.com/news_and_features/may2011/31turkmenistan_sets_up_space_agency.htm)

Gurbanguly Berdymukhamedov, president of Turkmenistan, has signed a decree authorising the creation of a National Space Agency "to ensure the implementation of scientific achievements in the national economy and to supervise future space exploration".

"The presence of own national satellite would boost the development of the country's communications network, Internet and television, contribute to the implementation of ecological programmes, and improve the exploration of energy resources."

There was no mention of where the country's Space Center would be headquartered.

The most likely program would see satellites built outside the country and launched by other space agencies on behalf of Turkmenistan, a nation with a small population of five million people and with a small industrial base.

Turkemenistan is part of Central Asia and vital ancient trade routes - notably "the Silk Road" went through its territory - see map:

[http://upload.wikimedia.org/wikipedia/commons/thumb/7/74/Silk\\_route.jpg/400px-Silk\\_route.jpg](http://upload.wikimedia.org/wikipedia/commons/thumb/7/74/Silk_route.jpg/400px-Silk_route.jpg)



Location of Turkmenistan relative to India

**More on Turkemistan**

<http://en.wikipedia.org/wiki/Turkmenistan> □

## IRAN

### Iran to launch a Monkey on suborbital ride

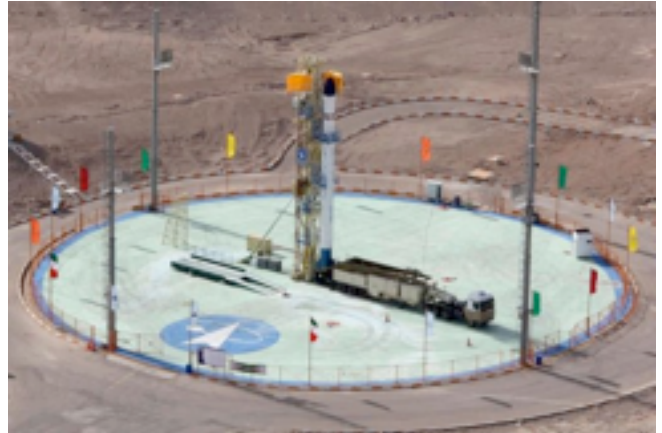

Iranian Launch Site: **Saffir** (Ambassador) rocket carrying Rassad-1 (Observation-1) satellite ready to launch into orbit 260 kms (163 miles) above the Earth on June 15.

<http://www.physorg.com/news/2011-06-iran-monkey-space.html>

The **Kavoshgar-5 rocket** will be launched during the month of Mordad (**July 23 to August 23**) with a **285-kg capsule** carrying a monkey to an altitude of **120 km**" said Hamid Fazeli, head of Iran's **Space Organisation [Sázmán e Fazái e Irán - <http://www.isa.ir/>]**.

This is a first step towards sending a man into space, scheduled for 2020. Small animals, a rat, turtles and worms, made the trip aboard a Kavoshgar-3 rocket in 2010.

It is not clear if the agency plans to recover the monkey alive or not, though it would make for positive publicity both in Iran and outside the country if it were recovered alive and in good condition.

For the history of monkeys in space (American and Soviet space programs) see:

[http://en.wikipedia.org/wiki/Monkeys\\_in\\_space](http://en.wikipedia.org/wiki/Monkeys_in_space)



Sam, a Rhesus monkey, flew to an altitude of 88 km in 1959. (NASA) 32 monkeys have made the trip. □

## Elsewhere in the Commonwealth



### UNITED KINGDOM

#### UK Space Program Gets Budget Boost

<http://www.bbc.co.uk/news/science-environment-12833654>

**23 March 2011 - Monies freed by regulatory changes and raised by other means will be used to “boost competitiveness of the UK Space Sector”**

- £10m will fund new technologies for spacecraft systems
- Changes will be made to the 1986 Outer Space Act “in relation to the liabilities that cover space operations”
- Reforms will lower insurance costs
- Space Sector growth in a Global Market is promoted
- Growth is sought in downstream activities - services such as satellite broadcasting and telecommunications, and in the upstream sector - such as satellite manufacturing
- Licensing will be clarified for emerging space tourism companies such as Virgin Galactic
- The goal is for UK Space sector to have a 10% share of the Global Space Market within a few decades

“The space sector is an unsung success story, supporting 70,000 jobs in the UK and generating £7.5 billion per year to the economy. Industry and government have in place a shared plan to grow this to £40bn and this additional investment will assist in achieving that aim.” □

### CANADA

#### Cash-flush MDA Corp. Looks Beyond Canada and the US for Growth

[http://www.spacenews.com/earth\\_observation/110302cash-flush-mda-looks-beyond-canada-for-growth.htm](http://www.spacenews.com/earth_observation/110302cash-flush-mda-looks-beyond-canada-for-growth.htm)



The ISS “Canadarm” is MDA’s pride and joy  
28 February, 2011 - “Canadian space hardware and services provider MDA Corp., flush with cash after selling its property information division, is hunting for an acquisition target in the United States, setting up offices in Moscow to harvest satellite communications contracts in that region and relocating its unmanned aerial vehicle military service business to Australia,”



Based in Richmond (Vancouver) British Columbia province of Canada, MDA is losing business through the retirement of the US Space Shuttles. MDA built the famous “Canadarm” remote operated arm on the International Space Station. To date, only the Shuttle has the capacity to deliver such massive components to ISS.

MDA “views tele-communications satellite opportunities in Central and South Asia as far more promising than in North America. The Canadian government had previously vetoed a purchase of MDA by ATK of Minneapolis, Minnesota, US.

MDA began to expand its operations outside Canada stating that Canadian government support to the space sector was slipping. “Canadian authorities have since increased their space spending to support Canadian industry, but not enough to keep MDA from running up against limits.”

The near-term need for numerous telecommunication satellites in Russia, Ukraine and the neighboring region is driving MDA to open a Moscow. □

#### 10 June 2011 - Canadian Space Agency Moves Forward with Executing Next Space Plan



The Canadian Space Agency (CSA) will see its budget peak this year at an all time high of \$424.6 million then drop 34% over the following two years as the government introduces its next “Long Term Space Plan.”

But this plan is still under wraps with no details or major points made public to date. An “internal structural reorganization” of the Agency, was completed in 2010 and consolidated CSA’s previous five primary program activities and one overlapping activity into four activities.

- 1. Space Data, Information and Services** - space-based solutions (data, information and services) and the expansion of their utilization. It also serves to install and run ground infrastructure that processes the data and operates satellites.
- 2. Space Exploration** - provide valuable Canadian science, signature technologies and qualified astronauts to international space exploration endeavours.
- 3. Future Canadian Space Activity** - attract, sustain and enhance the nation's critical mass of Canadian space specialists, foster Canadian space innovation and know-how, and preserves the nation's space-related facilities capability, encouraging private-public collaborations.
- 4. Internal Services** □

## AUSTRALIA



*Australia from Space*

### Australia's Plasma Thruster Could Get a Space Trial as Soon as 2013

[www.popsci.com/technology/article/2011-06/australias-plasma-thruster-could-get-space-trial-soon-2013](http://www.popsci.com/technology/article/2011-06/australias-plasma-thruster-could-get-space-trial-soon-2013)

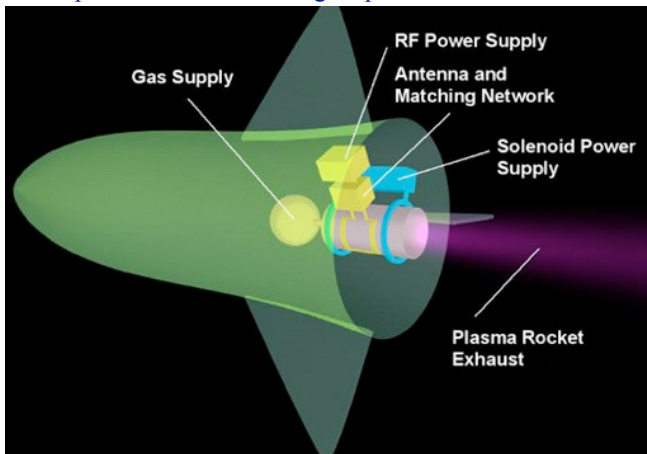

ANU's Helicon Double Layer Thruster, *Next Big Future*

23 June, 2011 - A \$3.1 million (Australian dollars) grant aims at getting promising plasma drive propulsion of the dream list and advance it towards reality. This would help Australian National University physicists to see their plasma engine make it to orbit aboard a European satellite within two years. This comes after ten years of work on their Helicon Double Layer Thruster (HDLT). This research is a collaboration between ANU, Surrey University, and the European space/aerospace contractor EADS-Astrium.

“Working plasma drives are sought after for their unparalleled bang-for-buck efficiency. Unlike chemical rockets that require huge amounts of propellant to achieve thrust, plasma engines can produce high exhaust velocities from relatively minuscule amounts of fuel.” In time, HDLT could derive a 5-hour burn in space from just one gram of propellant-- the amount of fuel chemical engines burn in an instant. “HDLT uses a shaped magnetic field to guide and accelerate a superheated gas plasma like Krypton or Xenon to high exhaust velocities, then expel it from a thruster.” The challenge is to keep that super hot plasma from burning up the engine itself.

Plasma engines do not generate the explosive acceleration such as do solid fuel thrusters, Their advantage is that their superior fuel-to-thrust ratios allow them to operate far longer on far less fuel, meaning more room for payloads. Not powerful enough to launch payloads into orbit, their usefulness comes in taking over from that point to boost payloads slowly but efficiently into higher orbits such as FEO or lunar orbit. The net result is more payload to key destinations at less expense.

As space propulsion to date has been quite inefficient, plasma thrusters will usher in a new age. □

## MALAYSIA

### June 23, 2011 – Malaysian Space Agency ANGKASA is developing “Malaysian Space Policy”

- Set out the vision and goals of Malaysian space activities for the new century
- Provide strategic context for investments in space exploration and exploitation by the Government and industry in order that they contribute effectively towards the socio-economic well being of the nation
- Mobilize and organize the resources (financial, manpower & institutional) to make such investments work for the nation in term of enhancing the productivity and skill-levels of the key economic sectors as well as the generation of high value added products, processes and services; and
- Establish the framework for the effective performance of the various actors involved in the exploration and exploitation of space including the engagement with external parties. □

## EAST AFRICA

### 4th African Leadership Conference on Space Science & Technology for Sustainable Development (ALC2011) set for Mombassa, Kenya, 26-28 September, 2011



[www.servirglobal.net/tabid/205/Article/919/4th-african-leadership-conference-on-space-science-and-technology.aspx](http://www.servirglobal.net/tabid/205/Article/919/4th-african-leadership-conference-on-space-science-and-technology.aspx)

The White Sands Beach Hotel, Mombassa, Kenya, is the site and the conference theme will be “**Building a shared vision for space in Africa.**”

**Algeria, Kenya, Nigeria and South Africa** are taking the lead, establishing **The African Leadership Conference (ALC)** as a biennial forum, and are in the forefront of an ongoing plan in the continent for development of an **African Resources and Environmental Management Satellite Constellation (ARMC)** Initiative. Other African nations may join in this venture to achieve far more than they could achieve each on their own. □





# Elsewhere in the World

With this issue, we add a new section.

**India is not only a major nation in Asia, and in the Commonwealth, but also in the World at large. So we expand our reporting to include the Space News in the US, in Latin America, in Europe, and Africa to nations outside Asia and the Commonwealth.**

## After 30 Amazing Years, the last of NASA's Remaining Three Space Shuttles is Retired

*Editorial Commentary* by Peter Kokh

### This was a long time coming

In the aftermath of the cancellation of the Apollo Moon Mission Program after the crew of Apollo 17 returned home from the Moon in December 1972, with three more landings already planned now “what ifs” of history, groups of disappointed space enthusiasts organized to lobby the American Congress for a new beginning, one on sounder foundations. The L5 Society, enthused by Gerard O’Neill’s vision of self-sufficient settlements in space housing workers who would build solar power satellites, began brainstorming “how we could get from here to there.” At about the same time, famed ex-German rocket scientist Wernher von Braun founded the National Space Institute to build public support for a new NASA initiative. The two organizations would merge to become the National Space Society at (L5’s) 6<sup>th</sup> International Space Development Conference in Pittsburgh, Ohio in March 1987.

Von Braun’s vision had two key elements: a space station (not the one we got, but a large rotating wheel with artificial gravity like that depicted in the Arthur C. Clarke/Stanley Kubrick 1968 epic Science-Fiction film **2001: a Space Odyssey**. Von Braun had also envisioned a series of shuttles that would fly to this station from Earth.

Well, we couldn’t sell Congress on the Space Station concept, not right yet, but there was interest from disappointed citizens and congresspersons in building a space shuttle that would take a crew and cargo into space for various missions. However, versions of Von Braun’s concept for a shuttle were dismissed as too expensive. NASA, after several non-productive bouts with Congress, finally got a Space Shuttle designed in part by NASA and in part by Congress which was motivated not by engineering and/or financial common sense, but by the local interests of key congressmen and senators from districts and states that would stand to benefit from the project.

Instead of a manned fly-back booster, we got the External Tank monstrosity with its dirty solid rocket boosters and a reusable External Tank, which, however, was never reused. The tank was jettisoned when it had reached 98% of orbital velocity and still had several tons of fuel

aboard. NASA was the guilty party here. The agency resisted all suggestions that if the External Tank had used the rest of its fuel to boost into a higher parking orbit that might preserve it for hundreds of years, we would have these structures with which to build many useful things in space in order to create a permanent ever expanding beach-head in space with orbiting hotels, industrial parks, and more. The grass roots space movement in the United States finally got Congress to mandate that NASA save the External Tanks for such purposes, but the Agency found a loophole and out of 135 launches, not one ET was ever left safely parked in orbit.

NASA promised us a fleet of four vehicles that between them could launch on a weekly schedule for \$100 million a launch. Instead we got a “Space Transportation System” that barely managed to launch 4-5 times a year, at one billion dollars a launch, ten times as costly. One of the problems has been the shuttle thermal tile protection system with no two tiles alike: very expensive to manufacture, and whose maintenance and replacement after each launch accounted for many of the “10,000 man-hours” of labor it took to turn around each shuttle. Can you imagine how much an airline ticket from Delhi to London would cost if at a stopover in Dubai, it took 10,000 man hours to get your aircraft airborne again!? Design by Committee, Design interference by Congress, lack of presidential leadership. All had a part to play. But this situation soon turned space enthusiast pride into despondency, then determination.

*Those of us who wanted settlement, not mere exploration*, were determined to get Congress to pass a Space Shuttle “**Sunset Act**” to require NASA to design a better transportation system and to encourage commercial companies to design man-rated launch systems, and most importantly, to give NASA a space shuttle retirement date: 2010. Well, NASA found a way to get three missions past that date, “needed to finish the International Space Station.”

Many younger generation Space Enthusiasts who have no knowledge of the history behind the Shuttle, are now discouraged that the last Shuttle has now flown. But most of us old-timers are elated. *Now the real space begins!*

To many Americans, NASA has become “as American as Apple Pie.” But this is a nation of free enterprise, a nation where “socialism” is a “dirty word.” It is amazing that it has dawned on so few Americans that NASA is a “socialized space program” – something that is definitely not “as American as apple pie.”

So while some space enthusiasts are despondent, many of the older ones are filled with hope, hope that with this false start out of the way, and the Constellation program too, we can really begin to build space infrastructure that makes sense, a program immune to Congressional interference motivated by irrelevant concerns.

We are also delighted that Space is becoming an International domain. The International Space Station seems immune to national mischief. That it involves international agreements gives it immunity to national politics. Now if we keep building systems with free enterprise, commercial economies, and international cooperation, the real space age should be about to begin, and to bloom, *in earnest*.

It’s time. The whole world should rejoice! **□**



**In Mexico,  
in Chile,  
in Argentina,  
and in Brazil  
Space is  
becoming a  
National  
Priority and  
National  
Pride**

[In this introductory piece, we want to bring readers up to date on the spectrum of space-related activities in Latin America, rather than focus on current space news.]

## MEXICO

**Mexico City** – 31.07.2010 – President Calderone signs a law creating the **Mexican Space Agency (AEXA)**

[http://en.wikipedia.org/wiki/Agencia\\_Espacial\\_Mexicana](http://en.wikipedia.org/wiki/Agencia_Espacial_Mexicana)

After years of discussion, Mexico, the world's most populous Spanish-speaking nation, and already playing a significant role in the field of Astronomical installations, is taking a small but epoch-making move to join the Space Age. AEXA's predecessor the Comisión Nacional del Espacio Exterior (CONEE) (*National Commission of Outer Space*), created in 1962, had conducted experiments in rocketry, telecommunications and atmospheric studies from 1962 to 1976. (Wikipedia)

AEXA begins with a small budget, charged with promotion of private investment and the creation of multinational aerospace companies. The bill requires the Agency to become a self-financing entity and not merely focus on research activities. AEXA headquarters are to be located in the state of Hidalgo, north of Mexico City.



The Large Millimeter Telescope in the state of Puebla

AEXA will coordinate existing space activities such as the Large Millimeter Telescope in the state of Puebla. Other centers will be dispersed around the country (city, state): Queretaro, Queretaro; Pachuca, Hidalgo; Ensenada, Baja California; and in Puerto Vallarta, Jalisco.

**Guadalajara** – Mexico's 2<sup>nd</sup> largest city in the state of Jalisco, is not to be ignored. The state has even formed its own space agency, so to speak, the **Jalisco Aerospace Committee (JAC)**, which is supportive of a Space Camp to include the Mex-LunarHab analog research station. □

[http://www.moonsociety.org/sem/MLH\\_Jalisco\\_project.pdf](http://www.moonsociety.org/sem/MLH_Jalisco_project.pdf)

## CHILE

**Santiago** – The **Chilean Space Agency ACE** is a party to a Regional Project involving Argentina (CONAE), Paraguay (CONACYT), and Uruguay (INIA) to promote and expand access to and use of satellite information sources as applied to agriculture and related businesses. The purpose is to set up a home network of satellite information for agricultural use collectively between institutions in Argentina, Chile, Paraguay and Uruguay.

ACE is also strongly supportive of the proposed **Moon/Mars Atacama Research Station – MMARS** – to be built in the Atacama, near the northern major port city of Antofagasta, operated by the University of Antofagasta. The Moon Society had a major role in development of the plans and program under consideration by U. Antofagasta.

MMARS could become the premiere site of Moon and Mars analog research worldwide. The Atacama, the world's driest desert, has been the location of significant research by NASA and leading exo-biology researchers. □

## ARGENTINA

16.08.2010 **Argentina plans to join the Space Age** and will build its own launch site at the Puerto Belgrano Naval Station, next to Punta Alta, near Bahía, about 700 km (435 mi) south of Buenos Aires. Argentina hopes to produce its own satellites and its own launch vehicle.

[http://www.upi.com/Business\\_News/Security-Industry/2010/08/16/Argentina-plans-to-join-Space-Age/UPI-15291281976235/](http://www.upi.com/Business_News/Security-Industry/2010/08/16/Argentina-plans-to-join-Space-Age/UPI-15291281976235/) □

## BRAZIL

Brazil successfully launched its first rocket into space on 23 October 2004 from the Alcântara Launch Center, at 2°17' S, the closest launch site to the equator in the world. The center is operated by the Brazilian Air Force.

[http://en.wikipedia.org/wiki/Centro\\_de\\_Lançamento\\_de\\_Alcântara](http://en.wikipedia.org/wiki/Centro_de_Lançamento_de_Alcântara)  
A civilian launching center, operated by the Brazilian Space Agency (*Agencia Espacial Brasileira*) is being built nearby.

AEB is a bilateral partner of NASA in the International Space Station and has provided equipment for ISS.

[http://en.wikipedia.org/wiki/Brazilian\\_Space\\_Agency#International\\_Space\\_Station](http://en.wikipedia.org/wiki/Brazilian_Space_Agency#International_Space_Station)

Brazilian Air Force pilot Marcos Cesar Pontes became the 1st Brazilian and 1st Portuguese speaking astronaut when he flew to the International Space Station in 2006. □

## MMM-India Quarterly Editors:



**Peter Kokh**  
[kokhmmm@aol.com](mailto:kokhmmm@aol.com)

[www.lunarpedia.org/index.php?title=Peter\\_Kokh](http://www.lunarpedia.org/index.php?title=Peter_Kokh)

Moon Society President  
Editor:  
[Moon Miners' Manifesto](#)



**Madhu Thangavelu**  
[thangavelu-girardey@cox.net](mailto:thangavelu-girardey@cox.net)  
Mother from Kerala, father from Tamil Nadu, grew up in New Delhi. Now teaching at U. Southern California. Conductor, Graduate Space Exploration Concept Synthesis Studio USC Schools of Engineering & Architecture



**David A. Dunlop**  
[dunlop712@yahoo.com](mailto:dunlop712@yahoo.com)

Moon Society Director of Project Development

Exec. Director of LUNAX (Lunar National Agricultural eXperiment)

University of Luna Project

We are proud to introduce our newest co-editors



**Srinivas Laxman**  
[moonshotindia@gmail.com](mailto:moonshotindia@gmail.com)

Mumbai

Space Journalist



**Pradeep Mohandas**  
[pradeep.mohandas@gmail.com](mailto:pradeep.mohandas@gmail.com)

Formerly President of SEDS India

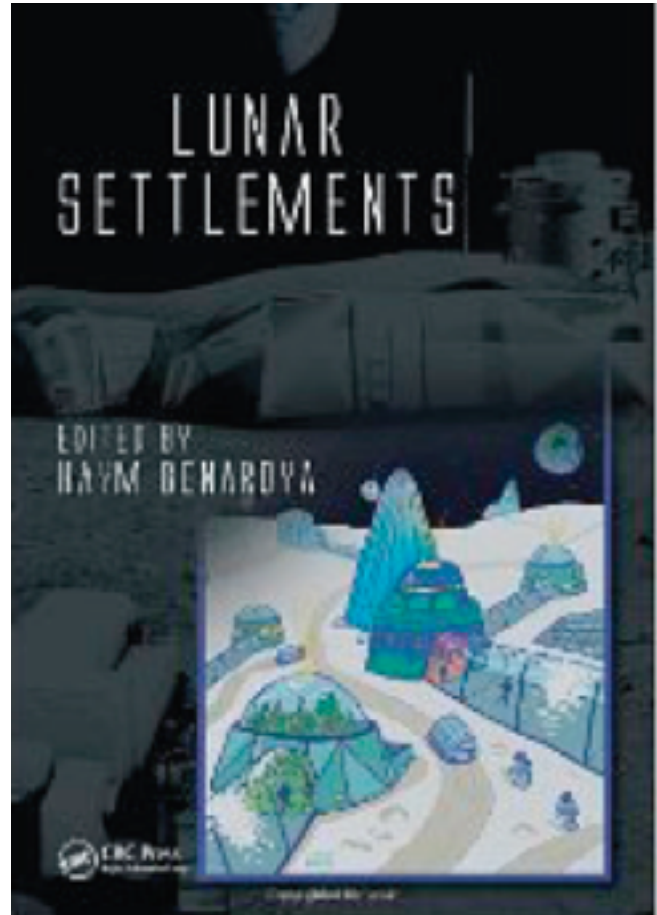

## Lunar Settlements

*A compilation of papers from the 2007 Rutgers University Symposium on Lunar Settlements*

(Advances in Engineering Series) [Hardcover]

[http://www.amazon.com/dp/1420083325/ref=as\\_li\\_tf\\_til?tag=nationalspa0a-20&camp=14573&creative=327641&linkCode=as1&creativeASIN=1420083325&adid=14F28Q00DXXETRJXJRZ8&](http://www.amazon.com/dp/1420083325/ref=as_li_tf_til?tag=nationalspa0a-20&camp=14573&creative=327641&linkCode=as1&creativeASIN=1420083325&adid=14F28Q00DXXETRJXJRZ8&)

**Editor Haym Bebaroya**

[http://www.amazon.com/Haym-Benaroya/e/B001HPZRNW/ref=ntt\\_athr\\_dp\\_pel\\_1](http://www.amazon.com/Haym-Benaroya/e/B001HPZRNW/ref=ntt_athr_dp_pel_1)

Hardcover: **801 pages**      **US \$150 = 6733 Rs**

Publisher: CRC Press; 1 edition (February 12, 2010)

Language: English

ISBN-10: 1420083325

ISBN-13: 978-1420083323

Product Dimensions: 23.5 x 15.7 x 4.2 cm

**Read the review by Steve Adamczyk**

[http://www.nss.org/resources/books/non\\_fiction/NF\\_105\\_lunarsettlements.html](http://www.nss.org/resources/books/non_fiction/NF_105_lunarsettlements.html)      **□**

# THE book WORM

**The Diary of a Space Traveler and Other Stories**  
By Satyajit Ray Translated By Gopa Majumdar

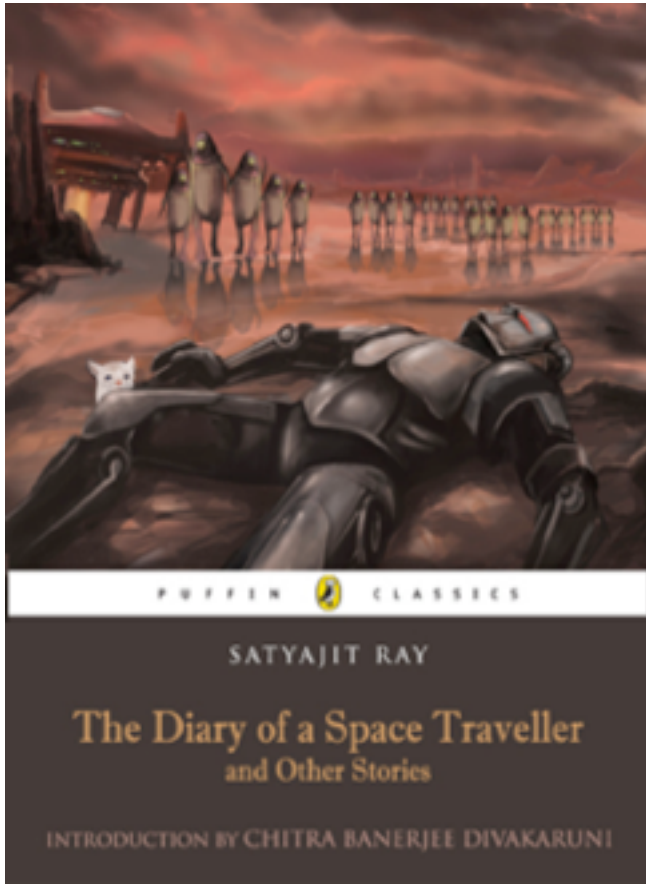

**Fiction** - Penguin Books India – RS 199

[http://www.penguinbooksindia.com/section/PENGUIN\\_CLASSICS/Puffin Classics/The Diary of a Space Traveller and Other Stories 9780143330905.aspx#](http://www.penguinbooksindia.com/section/PENGUIN_CLASSICS/Puffin%20Classics/The%20Diary%20of%20a%20Space%20Traveller%20and%20Other%20Stories%209780143330905.aspx#)

### Review from the page above:

“It all began with the fall of a meteorite and the crater it made. In its centre was a red notebook, sticking out of the ground—the first (or was it really the last?) of Professor Shonku’s diaries.

“Professor Trilokeshwar Shonku, eccentric genius and scientist, disappeared without a trace after he shot off into space in a rocket from his backyard in Giridih, accompanied by his loyal but not-too-intelligent servant Prahlad, his cat Newton, and Bidhushekhar, his robot with an attitude.

“What has become of the professor? Has he decided to stay on in Mars, his original destination? Or has he found his way to some other planet and is living there with strange companions? His last diary tells an incredible story...Other diaries unearthed from his abandoned laboratory reveal stranger and even more exciting adventures involving a ferocious sadhu, a revengeful mummy and a mad scientist in Norway who turns famous men into six-inch statues.”

Exciting, imaginative and funny, the stories in this collection capture the sheer magic of Ray’s lucid language, elegant style, graphic descriptions and absurd humour. The indomitable Professor Shonku has returned, to win himself over a whole new band of followers!” □

## Science Fiction in India

### Some Links

<http://indiascifiarvind.blogspot.com/2008/04/mahabharata-as-science-fiction-epic.html>

<http://www.indianscifi.com/>

[http://en.wikipedia.org/wiki/Category:Indian science fiction writers](http://en.wikipedia.org/wiki/Category:Indian_science_fiction_writers)

<http://indiascifiarvind.blogspot.com/2008/11/interesting-questionnaire-on-science.html>

<http://www.amazon.com/Classical-Science-Fiction-From-India/dp/B000S580KO> - mp3 download

<http://boingboing.net/2007/11/30/indian-ciences-ficti.html>

<http://users.rcn.com/singhvan/IndianSFF.html>

[http://www.penguinbooksindia.com/category/Science Fiction Fantasy.aspx](http://www.penguinbooksindia.com/category/Science_Fiction_Fantasy.aspx) - 6 books listed

### Do you have a Science-Fiction Story in You?

### Write for Moonbeams



[http://media.onsugar.com/files/2011/05/19/2/1642/16426432/12/science-fiction\\_wallpapers.jpg](http://media.onsugar.com/files/2011/05/19/2/1642/16426432/12/science-fiction_wallpapers.jpg)

[A scene from the yet to be released Science-Fiction film “John Carter on Mars” adapted from the classic Edgar Rice Burroughs novel with that title.]

Good stories grounded in sound science, help illustrate the possibilities of life on future space frontiers.

The Moon Society has a Science Fiction Publication in PDF file format called **Moonbeams**. Issues may be freely downloaded. Moonbeams is looking for good short stories: Check these links for more information:

<http://www.moonsociety.org/publications/fiction/>

[http://www.moonsociety.org/reports/moonbeams\\_rates.html](http://www.moonsociety.org/reports/moonbeams_rates.html)

□



**What if the Earth had Two Moons?**

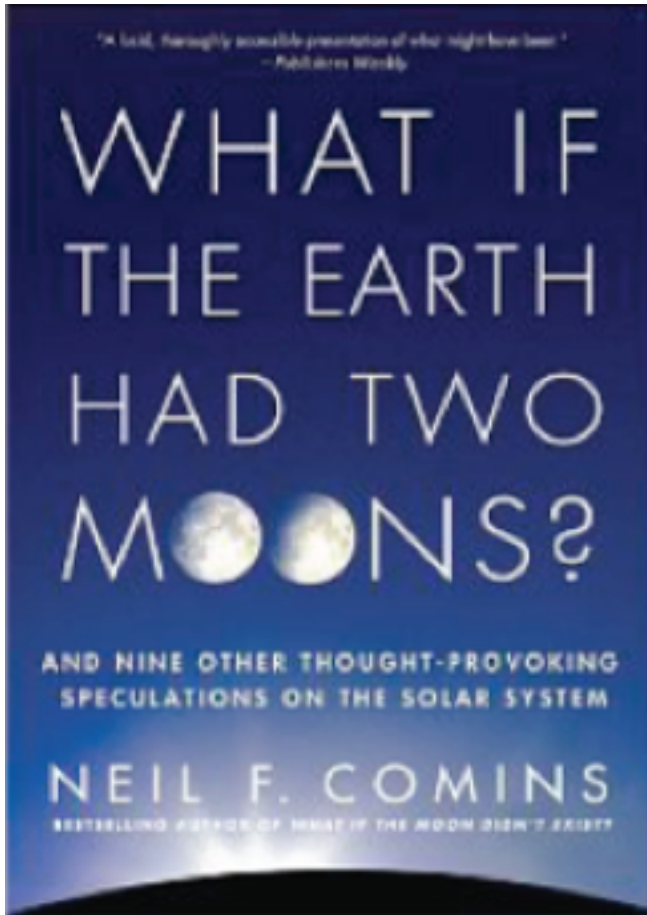

**By Neil F. Comins** - Review by Peter Kokh

Available from <http://www.amazon.com/>

By asking “What If” questions, we are challenged to reexamine our assumptions, and come to a new appreciation of “What Is.” The author is quite adept at this format, and has earlier published “What if the Moon didn’t Exist?”

The Two Moons question is just the first of several such essays in this book: Here is the full list.

- What if the Earth had two Moons?
- What if the Earth were the moon of a massive planet?
- What if the Earth orbited a less massive sun?
- What if the Earth had a thicker crust?
- What if the Moon orbited Earth in opposite direction?
- What if the Earth had two Suns?
- What if the Earth had a twin orbiting on the opposite side of the Sun?
- What if the Andromeda Galaxy collides with Milky Way?
- What if Earth formed closer to the center of our galaxy?
- What if the Earth formed in the distant future?

**Hardcover:** 304 pages - **Language:** English

**Publisher:** St. Martin's Press; 1 edition (March 30, 2010)

**ISBN-10:** 0312598920 - **ISBN-13:** 978-0312598921

Birger Johanson of Umea, Sweden had given me this book. It is much appreciated! I highly recommend it. ▣

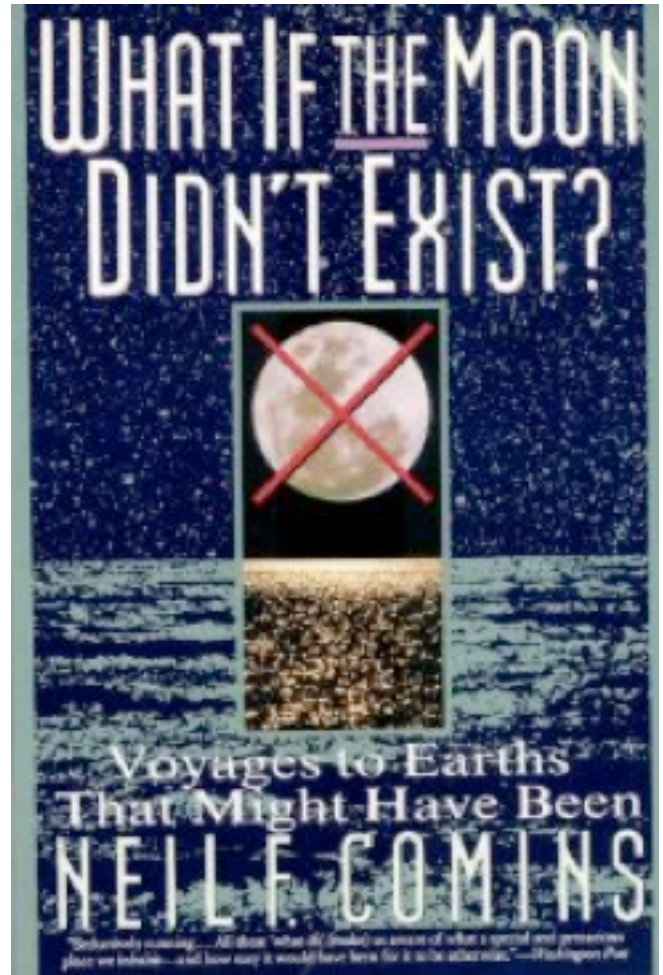

**What If the Moon Didn't Exist?:**

**Voyages to Earths That Might Have Been**

**By Neil F. Comins** - Review by Peter Kokh

Available from <http://www.amazon.com/>

This is Comins’ first essay into the world of “What Ifs” and it asks the most interesting question of all. The Moon’s tides by creating larger and more extensive tidal pools than those the Sun can rise (its proximity outweighing the puniness of the Moon’s mass) have almost certainly accelerated the development of Life on Earth. Its phases gave early man a convenient clock: the month. And that cycle drives biological cycles of many animals, including human women.

Our world, Earth, would be a very different place without the Moon. And unlike the other planets, which do not orbit Earth, but only the Sun, the Moon is clearly a part of Greater Earth, and an essential part of Earth as it has come to be. It is *an Eight Continent across another kind of Sea*, and the next goal in **mankind’s epic intercontinental saga “Out of Africa,”** and providing the leap into our next **InterpPlanetary** phase, with an **InterStellar** phase still in the distant future.

I highly recommend this book to all of us who try to foresee the place of the Moon in mankind’s future.

**Paperback:** 336 pages **Language:** English

**Publisher:** Harper Perennial (January 1995)

**ISBN-10:** 0060925566 - **ISBN-13:** 978-0060925567 ▣

# GREAT BROWSTING

## **SPACE TRANSPORTATION**

[www.colonyworlds.com/2011/03/cheap-interplanetary-travel-via-water-powered-rockets.html](http://www.colonyworlds.com/2011/03/cheap-interplanetary-travel-via-water-powered-rockets.html)

<http://www.popularmechanics.com/science/space/rockets/tech-behind-new-spacex-falcon-heavy-rocket-5518955#ixzz1KRTNQ7Ee>

<http://www.foxnews.com/scitech/2011/05/08/robonaut-humanoids-space-program/>

**From Paris to Tokyo in 2.5 hrs - EADS Hypersonic**  
<http://www.youtube.com/watch?v=8h1PE7StoDE>

**New Strategies for Exploration and Settlement**  
<http://www.thespacereview.com/article/1860/1>

**Human spaceflight for less: the case for smaller launch vehicles, revisited**  
<http://www.thespacereview.com/article/1861/1>

**Skylon in the crosshairs**  
<http://www.thespacereview.com/article/1865/1>

## **SPACE STATIONS, ISS**

[www.spacebridges.com/S3-blog-English/bid/60420/S3-infos-ISS-international-terminal-in-the-sky-historic-moment-this-week](http://www.spacebridges.com/S3-blog-English/bid/60420/S3-infos-ISS-international-terminal-in-the-sky-historic-moment-this-week)

<http://spacefellowship.com/news/art25556/station-crew-marks-10th-anniversary-of-robotic-arm-s-launch.html>

[www.businessinsider.com/china-space-station-2011-4](http://www.businessinsider.com/china-space-station-2011-4)

## **TECHNOLOGY**

<http://sg.news.yahoo.com/ideas-wanted-100-starship-project-darpa-nasa-122201770.html>

<http://www.colonyworlds.com/2011/03/what-off-world-farms-need-are-termites-and-ants.html>

**Beyond Cubersats, way beyond!**  
[http://news.yahoo.com/s/space/20110429/sc\\_space/shuttle\\_launchtocarryexperimentalcrackersizesatellitesintoorbit](http://news.yahoo.com/s/space/20110429/sc_space/shuttle_launchtocarryexperimentalcrackersizesatellitesintoorbit)

## **SPACE SOLAR POWER**

<http://space.algobus.net/papers/TowardsAnEarlyProfitablePowerSatPartII.pdf>

<http://mwcnews.net/focus/analysis/9477-the-race-for-space-solar-energy.html>

## **COMPETITIONS**

**NASA's X-Hab: Inflatable Loft Competition**  
<http://www.spacegrant.org/xhab/2011>

## **ANALOG STATION RESEARCH**

<http://www.sify.com/news/mars-spacesuits-unmanned-rover-tested-in-spanish-mining-desert-news-international-lfepughegd.html>

## **SPACE TOURISM**

<http://www.space.com/11477-space-tourism-options-private-spaceships.html>

<http://www.tgdaily.com/space-features/55784-moon-tourists-to-get-more-living-space>

## **PLANET EARTH**

<http://www.space.com/11930-nasa-launch-aquarius-satellite-ocean-saltiness.html>

[http://www.spacedaily.com/reports/The\\_Importance\\_Of\\_Being\\_Magnetized\\_999.html](http://www.spacedaily.com/reports/The_Importance_Of_Being_Magnetized_999.html)

**Is Earth Getting Full? - (Opinion Piece)**  
[www.nytimes.com/2011/06/08/opinion/08friedman.html](http://www.nytimes.com/2011/06/08/opinion/08friedman.html)

## **MOON**

[http://www.space-travel.com/reports/Looking\\_at\\_the\\_volatile\\_side\\_of\\_the\\_Moon\\_999.html](http://www.space-travel.com/reports/Looking_at_the_volatile_side_of_the_Moon_999.html)

[http://www.spacedaily.com/reports/LRO\\_to\\_take\\_extreme\\_close\\_up\\_of\\_eclipse\\_999.html](http://www.spacedaily.com/reports/LRO_to_take_extreme_close_up_of_eclipse_999.html)

[http://www.space-travel.com/reports/CMU\\_and\\_Astrobotic\\_Technology\\_Complete\\_Structural\\_Assembly\\_of\\_Lunar\\_Lander\\_999.html](http://www.space-travel.com/reports/CMU_and_Astrobotic_Technology_Complete_Structural_Assembly_of_Lunar_Lander_999.html)

[http://www.space-travel.com/reports/Parts\\_of\\_moon\\_interior\\_as\\_wet\\_as\\_Earth\\_upper\\_mantle\\_999.html](http://www.space-travel.com/reports/Parts_of_moon_interior_as_wet_as_Earth_upper_mantle_999.html)

**Lunar Wasystations: which is better: L1 or L2?**  
<http://www.thespacereview.com/article/1808/1>

**Case for Tidal Capture of Earth's Moon April 16, 2011**  
<http://wh-magazine.com/issue-printer/what-s-happening-magazine>

**ESA's proposed Lunar Lander and search for water**  
<http://www.spaceref.com/news/viewpr.html?pid=33715>

## **MARS**

[www.marsdaily.com/reports/Materials\\_for\\_Mars\\_999.html](http://www.marsdaily.com/reports/Materials_for_Mars_999.html)

<http://www.space.com/11907-mars-history-martian-illusions-human-delusions.html>

[http://townhall.com/news/sci-tech/2011/06/10/audit\\_mars\\_mission\\_faces\\_hurdles\\_before\\_launch](http://townhall.com/news/sci-tech/2011/06/10/audit_mars_mission_faces_hurdles_before_launch)

<http://www.colonyworlds.com/2011/04/the-key-towards-mars-is-deimos.html>

[http://www.theregister.co.uk/2011/04/21/musk\\_mars\\_drag\\_on\\_claim/](http://www.theregister.co.uk/2011/04/21/musk_mars_drag_on_claim/)

<http://science.slashdot.org/story/11/04/22/189202/http://science.slashdot.org/story/11/04/22/189202/The-Space-Station-As-a-Simulated-Mars-Mission>

**Small Mass of Mars Could Be Due to Planetary Orbital Migration**

[http://www.marsdaily.com/reports/New\\_solar\\_system\\_formation\\_models\\_indicate\\_that\\_Jupiter\\_foray\\_robbed\\_Mars\\_of\\_mass\\_999.html](http://www.marsdaily.com/reports/New_solar_system_formation_models_indicate_that_Jupiter_foray_robbed_Mars_of_mass_999.html)

**ESA-NASA 2016 Exo-Mars Trace Gas Orbiter mission**  
[www.esa.int/esaSC/SEMLEFRHPOG\\_index\\_0.html](http://www.esa.int/esaSC/SEMLEFRHPOG_index_0.html)

**Camera duo on Mars rover will shoot color views**  
[www.spaceref.com/news/viewpr.html?pid=37286](http://www.spaceref.com/news/viewpr.html?pid=37286)

## **OTHER PLANETS**

<http://www.space.com/12003-venus-mysteries-cosmos-universe.html>

<http://www.allvoices.com/news/9395727-nasa-cassini-unlocks-saturns-secrets-top-10-pictures>

## **ASTEROIDS**

[http://www.spacedaily.com/reports/Dawn\\_Nears\\_Start\\_of\\_Year\\_Long\\_Stay\\_at\\_Giant\\_Asteroid\\_999.html](http://www.spacedaily.com/reports/Dawn_Nears_Start_of_Year_Long_Stay_at_Giant_Asteroid_999.html)

<http://news.softpedia.com/news/NASA-Studies-Three-Proposals-for-major-2016-Mission-198821.shtml>

### ASTRONOMY

**Mauna Kea Observatories, Hawaii Island**

<http://www.ifa.hawaii.edu/mko/>

### EXTREME LIFE

<http://www.newscientist.com/article/dn20534-goldmine-worm-shows-animals-could-be-living-on-mars.html>

### NATIONAL SPACE AGENCIES

<http://spacefellowship.com/news/art25564/india-puts-three-satellites-into-orbit.html>

**UK Space Agency launches in Swindon**

<http://www.bbc.co.uk/news/uk-12879219> (with video)

**UK space given boost from Budget**

[www.bbc.co.uk/news/science-environment-12833654](http://www.bbc.co.uk/news/science-environment-12833654)

**ESA and the advantages of the Collective Approach**

<http://www.thespacereview.com/article/1843/1>

### SPACE ART

**50 Years of NASA Space Art**

<http://www.thespacereview.com/article/1854/1>

**Future Dreams**

<http://www.worldof2001.com/>



<http://www.space.com/11242-strange-craft-mojave-sky-theyre.html>

<http://online.wsj.com/video/elon-musk-ill-put-a-man-on-mars-in-10-years/CCF1FC62-BB0D-4561-938C-DF0DEFAD15BA.html>

(fast forward to 13:05 on 15 minute video)

<http://www.space.com/11945-dark-feature-spotted-asteroid-vesta.html>

<http://www.bigislandvideonews.com/2010/02/05/video-hawaiis-lunar-like-mauna-kea-hosts-space-tests/>

**Two Sides Has the Moon & Here's What's On Then**

<http://www.space.com/9859-sides-moon.html>

**Inside of the Space Station from one end to the other**

[http://www.youtube.com/watch\\_popup?v=H8rHarp1GEE](http://www.youtube.com/watch_popup?v=H8rHarp1GEE)

(the music is hardly celestial! you may want to turn off the cacophonous sound!)

**Space-X to demolish prices to orbit and anywhere else**

<http://www.youtube.com/watch?v=DtoADdSry6g>

**A Year Over the Moon's North Pole**

<http://www.youtube.com/watch?v=Tu3daa98aoI>

**Jeff Greason: A Settlement Strategy for NASA**

<http://www.nss.org/resources/library/videos/ISDC11greason.html>

<http://www.space.com/11945-dark-feature-spotted-asteroid-vesta.html>

<http://www.bigislandvideonews.com/2010/02/05/video-hawaiis-lunar-like-mauna-kea-hosts-space-tests/>

**Space Settlement Videos:**

Torus - <http://www.youtube.com/watch?v=oazFe2jbMxw>

Flythru - [www.youtube.com/watch?v=9PYOgQEiBu4](http://www.youtube.com/watch?v=9PYOgQEiBu4)

[ [Links to many more similar videos](#) ]

## Moon Miners' Manifesto Resources

<http://www.moonsociety.org/chapters/milwaukee/mmm/>

MMM is published 10 times a year (except January and July). The December 2010 issue will begin its 25<sup>th</sup> year of continuous publication.

Most issues deal with the **opening of the Lunar frontier**, suggesting how pioneers can make best use of **local resources** and learn to **make themselves at home**. This will involve psychological, social, and physiological adjustment.

Some of the points made will relate specifically to **pioneer life** in the lunar environment. But much of what will hold for the Moon, will also hold true for **Mars and for space in general**. We have one Mars theme issue each year, and occasionally **other space destinations** are discussed: the asteroids, Europa (Jupiter), Titan (Saturn), even the cloud tops of Venus.

Issues #145 (May 2001) forward through current are as pdf file downloads with a Moon Society username and password. Moon Society International memberships are \$35 US; \$20 students, seniors – join online at:

<http://www.moonsociety.org/register/>

**MMM Classics:** All the “non-time-sensitive editorials and articles from past issues of MMM have been re-edited and republished in pdf files, one per publication year. A 3-year plus lag is kept between the MMM Classic volumes and the current issue. **As of December 2011, the first twenty-two years of MMM, 200 issues, will be preserved in this directory**, These issues are freely accessible to all, no username or password needed, at:

[www.moonsociety.org/publications/mmm\\_classics/](http://www.moonsociety.org/publications/mmm_classics/)

**MMM Classic Theme Issues:** introduced a new series to collect the same material as in the Classics, but this time organized by theme. The first MMM Classic Theme issue gathers all the **Mars** theme articles from years 1-10 in one pdf file. A second pdf file collects all the Mars Theme issues from year 11-20. The 2<sup>nd</sup> Classic Theme is “**Eden on Luna**,” addressing environmental issues underlying lunar settlement. **Asteroids, Tourism, Research, Select Editorials, and Analog Programs** have been added. New Theme Issues will be coming: Lunar Building Materials, The Lunar Economy, The Lunar Homestead, Modular Architecture, Modular Biospherics, Frontier Arts & Crafts, Frontier Sports, Other Solar System Destinations, and so on.

[www.moonsociety.org/publications/mmm\\_themes/](http://www.moonsociety.org/publications/mmm_themes/)

**MMM Glossary:** The publishers of MMM, the Lunar Reclamation Society, has published a new Glossary of “MMM-Speak: new words and old words with new meaning” as used in Moon Miners' Manifesto.

[www.moonsociety.org/publications/m3glossary.html](http://www.moonsociety.org/publications/m3glossary.html)

The initial addition includes over 300 entries, many with illustrations. Additional entries are under construction. It is hoped that new members will consider this to be a “Read Me First” guide, not just to Moon Miners' Manifesto, but to our vision and goals.

**All of these resources are available online or as free access downloads to readers of MMM-India Quarterly**

# M3IQ PHOTO GALLERY



NASA's "X-Hab" lower floor to which is to be mated an "inflatable loft" the design of which is the subject of a competition: <http://www.spacegrant.org/xhab/2011> Read "Exploring the Many Possibilities of Hybrid Rigid-Inflatable Structures" pages XX-XX, below

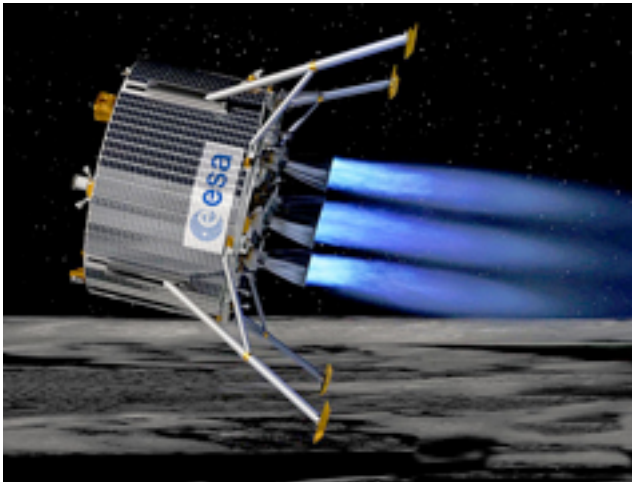

ESA's Proposed Lunar Lander (for 2018 mission)  
<http://www.spaceref.com/news/viewpr.html?pid=33715>

## Photos from Mercury MESSENGER now in orbit

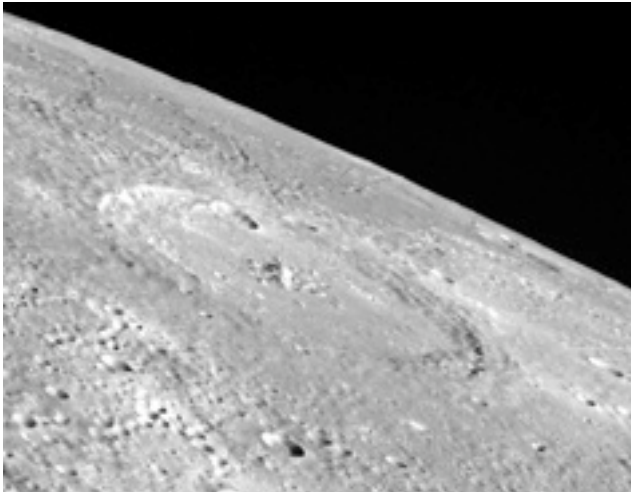

Crater Verdi

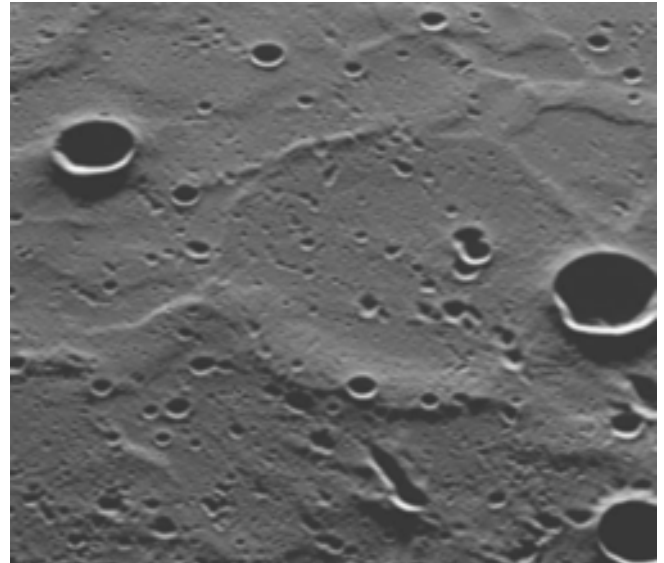

Smooth area near north pole – 60mi across at bottom



Newly constructed launch facility for Russian **Soyuz** rockets at the European Space Agency's spaceport in **Kourou**, French Guiana in South America will allow Russia to launch rockets from much closer to the equator.  
[http://www.spacedaily.com/reports/Soyuz\\_Launch\\_Site\\_Ready\\_For\\_First\\_Flight\\_999.html](http://www.spacedaily.com/reports/Soyuz_Launch_Site_Ready_For_First_Flight_999.html)

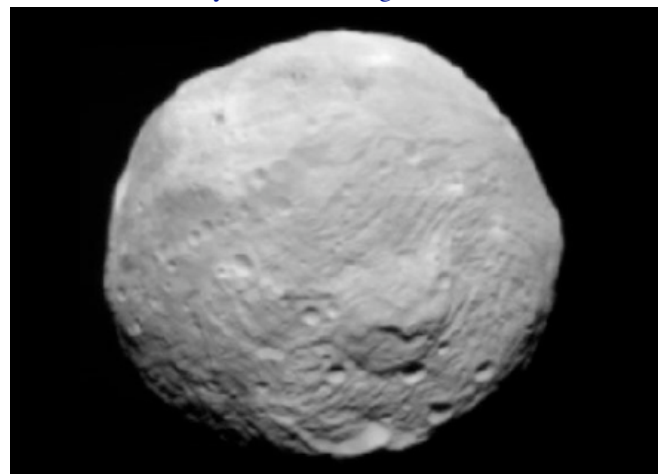

[http://www.spacedaily.com/reports/Dawn\\_Nears\\_Start\\_of\\_Year\\_Long\\_Stay\\_at\\_Giant\\_Asteroid\\_999.html](http://www.spacedaily.com/reports/Dawn_Nears_Start_of_Year_Long_Stay_at_Giant_Asteroid_999.html)



## Human Space Activity: The Spiritual Imperative

By Madhu Thangavelu

When the Pope called the ISS crew, to ask how they felt floating over our fragile blue planet, whether they see ravages of war, and what they think of it, and if the crew pray on-orbit, one wonders what's on the pontiff's mind and agenda. Religion and scientific pursuits parted company centuries ago, at least in the eyes of the public, most notably during the historical inquisition of Galileo, a devout christian. How dare a commoner employing lowly empirical objective logic challenge the supreme authority, especially on heavenly matters.

Religion and science have butted heads before and after Galileo and continues to seek common ground, but to the layman the philosophies are irreconcilable. How can we expect a dogma that rests their case at every turn on divine intervention to come to terms with one that employs impeccable logic coupled with incremental data gathering to bolster evidence to arrive at their conclusions ?.

The Sun and the Moon, the most prominent orbs that grace our skies, have a deep-rooted significance in every great religion as well as in Science which employs state of the art technologies to explore and understand these celestial bodies in our neighborhood, and yet the philosophies could not be further apart. Perhaps that is how it is meant to be ? Often, opposing philosophies are needed for the fertile mind in order to create imaginative products.

People are born into religion and ritual and end their lives in the same way, even though most of us stray away from organized religion and liturgy for most of our lives. Never do we hear of a scientifically accurate christening of a new arrival or send-off for the soul of the departed. Religion and spirituality console and comfort the human soul in a way that science cannot.

After all, religion was the primary purveyor of science, and especially astronomy, as is evident in the images projected in cathedrals and churches and temples all over the world. The heavens belonged to God and religion. Even today the architecture of religious structures, alters and prayer spaces around the world aspire to the heavens and some elaborate geometries are summoned in their planning and design. It is interesting to note that the term "Big Bang", although coined by Fred Hoyle, referring to the birth of our universe, was conceived by a clergyman, Monsignor Georges Lemaitre of Belgium.

Albert Einstein once responded to a question about his religious beliefs by saying that that he was utterly in awe and wonderment as nature slowly gave up her secrets, and that he was a religious practitioner of Science in that respect. Here we see a thought linking religion and spirituality. I think he was referring to spirituality, the essence of all religion, the belief in a supreme power of nature, that seems to run the universe with some, yet to be wholly grasped supralogical processes, with ultra-mathematical precision that Vivekananda refers to in his lecture on Immortality delivered at the Chicago World's Fair in 1893. Even atheists find the power of nature overwhelming.

Now, this unfathomable power seems to run into trouble with conventional scientific thought all the time; just

ask Stephen Hawking or Richard Dawkins. Of course, it is taboo to bring up issues relating to religion or spirituality in modern scientific discussion, though many scientists are privately very spiritual in their beliefs. It is worthwhile to note that doctors practicing modern medicine use spirituality and prayer in the healing process, and hospitals have religious or non-denominational spaces just for patients.

A definition that encompasses both of these great philosophies is that proposed by Tolstoy in his essay entitled "Confessions" in which he presents the idea that the greatest science of all is the science of the universe and humanity's place in it. He paints the range of human thought as that anchored at one end by theology and on the other by pure mathematics; no reconciliation this, but at least puts philosophies along a continuum of human thought without walls.

In this prevailing context, the Templeton Foundation finds itself almost singularly looking for answers about how to reconcile the ever widening schism between the different dogmas of Science and Religion and seeks out works that try to bridge the chasm. Notable winners of this prize that now approaches or even exceeds the Nobel in monetary value include such luminaries as the humanitarian Mother Theresa, the evangelist Reverend Billy Graham, and Freeman Dyson, the sage of Princeton Institute of Advanced Studies and physicist John Polkinghorne. This year the prize went to none other than Lord Martin Rees, royal astronomer to the queen of England and past president of the Royal Society.

Had this prize been established long ago, several luminaries of modern science might have been honored by it. They might have included Sir Isaac Newton for his work on unifying the Holy Trinity and Mohandas Gandhi who preached that practicing science without humanity is a great moral sin. And Vernadsky and de Chardin who forecast the emergence of the global brain. Both sought a highly refined global consciousness in the Noosphere and the Omega point concepts, to be attained by man as humanity becomes more aware and sensitive to our surroundings. Little did either of them foresee the invention of the internet and the worldwide web and the electronic social media revolution that is reshaping nations, but this is the track that our communications and information technologies are racing on, creating a new level of situational awareness, sensitivity and freedom of expression.

Seeking new models for rapidly evolving governance of societies, moving from nationalism to internationalism and beyond, grappling with global issues and the economics of globalization, we seem to be at the threshold of a newly refined era . Globalism, a wholesome view of our planet and all its contents, the integration of the stewardship of planet Earth and nature in the wake of the effects of climate change, we are coming full circle to embrace the mystical philosophy of transcendentalism, articulated nearly two centuries ago by Thoreau and Emerson and others.

As I write, an extensive 3-year study has just appeared out of Oxford University by Prof. Roger Triggs, the Cognition, Religion and Theology Project, in which he points to the fact that we cannot separate religion or religious customs, ritual and culture from the humanities, and

that as much as science is a determining philosophy in the progress of great societies, religion plays a crucial role in the development of man and in the foundational organization of great societies. In fact, children around the world are introduced to, and quicker to absorb the notions of God and spirituality, even before they start to appreciate and use logical reason. Prof. Triggs may be aiming for the next Templeton prize, but this appears to be a very important effort, especially since the long simmering tensions as well as the recent events unfolding in the Middle East seem to have a solid bearing on religion.

While science and applied technologies have us mastered in the art of uplifting the masses economically, indeed it is religion (in its extreme and corrupt forms?), rituals and customs that have been used time and again, as effective vehicles of mass destruction to accomplish the goal of demoralizing and decimating populations. On the other hand, it is religion that has also assuaged the needs of people battered both by war as well as natural disasters. Clearly, we are dealing with a highly potent weapon of two sharp edges.

Religion stripped of all customs and liturgical practice may be termed spirituality. It is the essence of wonderment that explorers feel when they are exposed to nature's secrets and subject to awe-inspiring new dimensions in human experience. The great director Peter Brooks once said that the manmade world around us is conspiring at every moment to rob us of our sense of awe and wonder that the universe and nature continually presents to us.

NASA spends a lot of time and resources focusing on the technology that sustains human space explorers engaged in scientific exploration: a term used to say that these highly specialized professionals are engaged in the pursuit of scientific discovery. It is a very narrow view of human space activity. Space commerce is brimming with ideas beyond the mature and revenue generating satellite communications field that are awaiting exploitation, among them, beaming solar energy from space and providing extensive refueling operations for outbound vehicles. It is well known among engineers that erecting and deploying large structures such as the ISS or endurance-class spacecraft and space based solar array farms require on-site human supervision. These crew will find spiritual solace after a hard day's work, looking out at the Earth disc, from their private quarters in orbit.

As the government astronaut corps around the world continue to shrink, a growing number of human space explorers are wealthy individuals without the professional background or rigorous training of government astronauts. They are seeking to experience spaceflight, to feel outer space in their bellies and souls, and to directly witness the fragile planet while floating above it, and the driver seems to be spirituality; physically seeking, experiencing and appreciating man's place in the universe. We call them space tourists. Space adventurers or spiritual tourists, a better term, perhaps?

Are there areas of science and technology that weave into religion and spirituality? It appears that human space activity offers a venue to explore possibilities. While robotic spacecraft roam the solar system, sending us

intriguing images from worlds afar, the yearning of humanity to be physically present there is what drives NASA and others to pursue space exploration. Without a vibrant human space activity component, NASA may not have a reason to exist.

As the crew liftoff into orbit, though their eyes are on the glass cockpit and their ears tuned to mission control jargon above the roar of those mighty engines, they are praying for a successful and smooth launch. As the boosters fall off and the ride becomes much smoother, they start to see nature's spectacle through the windows. Again their minds and eyes, though tuned to the mach numbers steadily climbing higher than twenty times the speed of a rifle bullet, are beholden by the awe of the space environment. A few minutes later, after the final thrust that puts them into orbit, and their bodies released from the force of gravity, their minds are fully overtaken by the awesome majesty of the Earth's disc. They are experiencing a spiritual awakening that words cannot express adequately.

Upon arrival at ISS, the first thing on their minds is to look out at planet Earth. The ISS now sports the Italian made cupola, a large and exquisite window that looks toward planet Earth, and it is perhaps the most aesthetic component of the entire facility. Of course, it is no secret that ISS crew spend a lot of their free time just looking out this cupola and marveling at the dynamic colors and drama the Earth gliding below them offers, even as the day becomes night and back again, all in a matter of minutes, as they orbit the planet. As they gaze at Earth through this large cupola, crew are immersed in a spiritual experience. I have had astronauts stare me in the eye when posed the question, how does it feel to be walking on the surface of the Moon?

Human space explorers seek that spiritual experience and are willing to risk their lives for it. Well, you really have to be there to experience it, they say. Words won't do. It appears their sensory systems are turned up to highest alertness levels, heartbeats racing like athletes during peak performance, and they are soaking in terabits of information, and this rush of data is simply too hard to debrief, in technical terms, prose or poetry. When faced with such a high, though they are fully aware that it is Newton and Kepler's Laws that guided them there, their minds and souls quickly gravitate toward the scriptures. And human space explorers seek that intense spiritual experience and are willing to risk their lives for it.

Most crew of space missions come back changed forever. This phenomenon is addressed in several books, notably in the Overview Effect by Frank White. Astronauts do not see national boundaries, they do not see warring nations, and they rarely notice the ravages of humanity and industry on the face of the planet. All they see is a stunningly vibrant planet, lots of blue ocean, virgin white snow tops on mountain ranges and puffs of cloud cover as the continents whizz by below them in absolute silence, no one asking them for country of origin or standing in line for visa verification. They see the whole world as one entity, and globalism becomes reality from orbit.

In worldly affairs and governance, in daily life and commerce, culture and religion, ritual and spirituality all

trump over science and technology every time. Science and technology are but tools, sophisticated tools of our time, merely used only to fulfill human urges and nourishment for our soul. When faced with the wonder and awe of nature, humans always gravitate toward spirituality. That is why when Apollo 8 was injected into orbit the crew recited from Genesis and Aldrin made communion as he stepped on the Moon.

In November of 2009, marking the International year of Astronomy, the Vatican was host to an Astrobiology study week. Presided over by the Pope’s chief astronomer, the gathering of over 30 professional astronomers including Templeton winner Paul Davies and Jill Tarter of the SETI Institute pondered the meaning of extraterrestrial life. They agreed that the bounty of God allows for life in other parts of our universe and does not pose a conflict with religious philosophy.

Yes, perhaps human spaceflight can bring science and religion closer together as more people from various nations, cultures and walks of life experience space first hand. Perhaps the Pope had these thoughts of science-technology-theology synergy in mind when he dialed that ISS number in-orbit? Let us wait now to see what the Dalai Lama and Sri Sankara of Kanchipuram, the chief Rabbis and those Imams of Mecca and Ayatollahs have to ask of our brave crew in orbit.

**Editor’s Note:** The above essay is the original unabridged version of a piece that has since been published on a blog:

<http://religion.blogs.cnn.com/2011/07/06/my-take-space-travel-is-a-spiritual-experience/comment-page-1> □

**On the topic of the spiritual and cosmic effect that exploration of space has had on our cultures, we highly recommend this classic book by Frank White:**

**The Overview Effect:  
Space Exploration and Human Evolution**

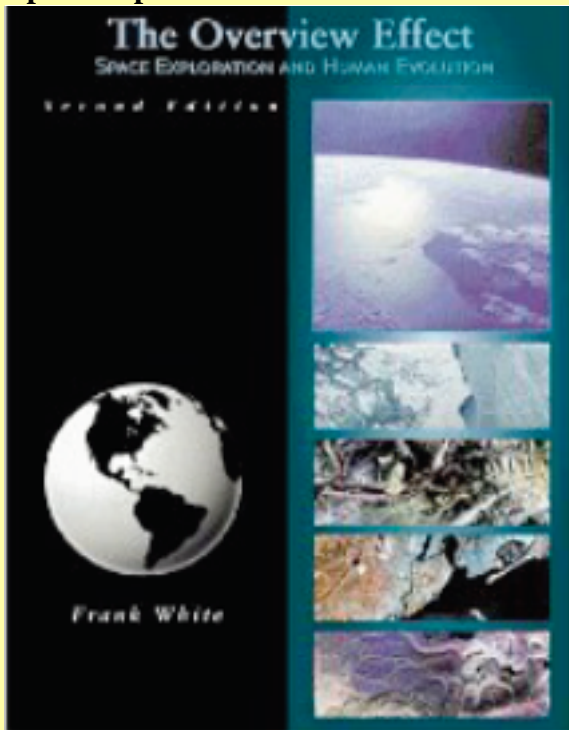

**International Space Projects Make Sense  
Should we not pursue them under one flag?**

Comments by Peter Kokh



The above “Blue Marble” flag has been proposed as the “One Flag in Space” by the Blue Marble Foundation

<http://www.oneflaginspace.org/>

On the surface of it, this proposal seems to be impossible. What face of the globe would we use? We are an “intercontinental species!” The answer is simple, logical, and elegant. One thing all humans have in common is our original homeland: Africa, and the chosen design zooms in on that unifying factor.

Not only can this symbol complement the flag of the United Nations and UNESCO, but it unites us in general by reminding us all of our common roots and origins. But it is its use for International Space Projects, such as the International Space Station (though ISS is a “limited” international partnership – *so far*) and the proposed International Lunar Research Park that has our interest.

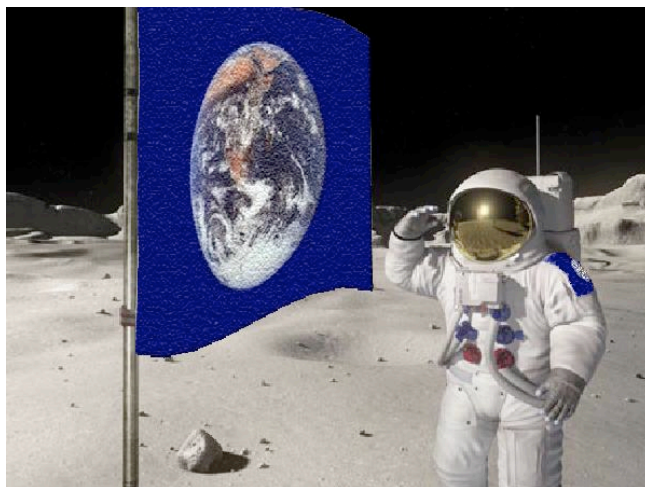

Above; an astronaut (cosmonaut, taikonaut, spacionaut, vyomanaut etc.) on the Moon, salutes the proposed flag.

While this seems like a great proposal, for now we should perhaps just consider it that: a proposal. Not all space enthusiasts have an international perspective. Many people, proud of their own nation’s achievements in space, or enthused about their nation’s plans for space activities will be interested in flying a flag uniting us all. □



## “The Case For Going to the Moon”

By Neil Ruzic

Review by **David Dunlop**, The Moon Society

I received a generous gift from Ken Murphy who surprised me with a book I had long wanted to see but had never found: **The Case For Going to the Moon by Neil Ruzic**. This book was published by Putnam in 1965, well before the Apollo landings, and the contemporary understanding of the Moon that derived from those missions. Mr. Ruzic was the publisher and editor of the magazine *Industrial Research*, and was widely acquainted with the scientific community of the day.

Arthur C. Clarke wrote the Forward to the book and other endorsements included those from Herman Kahn of the Hudson Institute, and Dandridge M. Cole of General Electric. I think the book is quite remarkable for its time and looks ahead to the rationale for a scientific and industrial agenda as justifications of this great enterprise at a time when the frenzy of the cold war competition between the US and the Soviet Union was at its height.

Ruzic asks “what good is the Moon?” and cites the answer physicist James Clerk Maxwell gave to a similar question: “What good is a baby?” Ruzic answers: “This undeveloped child of the Earth we call the Moon is a goal, a treasury of information, and a desirable platform in space. Practical scientific, industrial and humanitarian reasons for going to the Moon include:

- Employing its unique environment for research and manufacturing,
- Mining it for useful materials and significant geological knowledge;
- Locating on it meteorological and astronomical observatories, hospitals, and biological laboratories
- Developing it as a space port from which to explore the solar system and the universe; and
- Utilizing its by products to massively stimulate our economy and to help prevent war.”

### **Lunar Industrial Utilization**

Forty-five years after its publication and almost than forty since the last Apollo mission of 1972, it is sad to see that the scientific agenda and industrial rationale Ruzic lays out is still unfulfilled. The challenge of the utilization

of the Moons' resources still remains and has only been reinforced by the recent writings of Paul Spudis and Tony Lavoie (1) about ice mining production and the call of Jeff Greason (2) to go to the Moon “to make gas.”

In retrospect it is hard to remember that the Apollo program was not widely supported in either public sentiment or in the scientific community. Ruzic sent out seven surveys about going to the Moon, which included over 1,000 engineers and scientist in each of the seven mailings. Some 60% indicated they didn't care about the Moon and over 16% indicated they were opposed to spending the money to go. His agenda in the face of such indifference and opposition is still relevant in the not so different climate that prevails today.

Since the end of the Apollo program, the American public has also not shown sufficient passion to sustain the momentum of the Apollo era and to advance further in the goal of settling the Moon. So things haven't really changed that much since the 1960's. Perhaps the new international space race and pressures of economic competition in Asia between China, India, and Japan and with Europe will bring the US back to the lunar surface. The current retreat from the Moon is otherwise a symbol of its economic decline and of the government's seeming lack of a national will to compete.

### **Lunar Vacuum**

The book lays out a research agenda in several dimension beginning with those connected to high vacuum and materials science. Work which we now refer to as nanotechnology is discussed in terms of thin films, precision “doping”, metallurgy, welding, and coating applications He discusses spectroscopic advances, the potential of vacuum tube applications, super conductivity research and micro miniaturization as being facilitated by the advantages of the lunar vacuum.

Ruzic also carries these arguments forward in considerable detail with regard to lunar advantages in manufacturing resulting from both vacuum conditions and cryogenic conditions on the Moon. He also points out that the low lunar gravity provides advantages in the transportation of lunar derived manufactured materials off the lunar surface while the atmosphere of the Earth provides the use of aerobraking in their delivery. On page 71 he points out the reduction of transportation cost can be achieved by “refueling in orbit with Moon processed fuel.” This conclusion was latter revisited and confirmed by Dallas Bienhoff and his colleagues at Boeing during the 1990's in their studies of the advantages of orbital refueling and lunar fuel production (3) and by Kent Joosten and Lisa Guerra in their 1993 paper “Early Lunar Resource Utilization: A Key to Human Exploration.” (4)

In a recent interview at the 2011 International Space Development Conference in Huntsville, Alabama, US, Ken Murphy discussed the idea of creating glass spheres capturing a vacuum in space and thereby “selling nothing for a fair price”. (5) Here again Ruzic suggests the very same thing on pages 77 “to send “some” of the Moon vacuum and lunar cryostat-produced “cold” back to Earth”... it is conceivable that a sealed simple pressure-shell

containing literally nothing inside, or an insulated package of a material cooled to 10K or lower, with suitable “vacuum locks,” could be shipped to Earth, ports intact- for a price less than evacuation or liquid helium cooling on mother Earth.”

He concludes his chapter with the statement “only when knowledge (the simplest and most important commodity to ship) and locally manufactured materials are exported one way to Earth will the Moon begin to achieve its ultimate potential.”

### **Lunar Industrial Utilization**

Forty-five years after its publication and almost than forty since the last Apollo mission of 1972, it is sad to see that the scientific agenda and industrial rationale Ruzic lays out is still unfulfilled. The challenge of the utilization of the Moon’s resources still remains and has only been reinforced by the recent writings of Paul Spudis and Tony Lavoie (1) about ice mining production and the call of Jeff Greason (2) to go to the Moon “to make gas.”

There is a chapter on lunar mining and extensive discussion on the potential of capturing volcanic gases from the Moon. There is a discussion of admittedly controversial reports of gaseous clouds emanating from Alphonsus central peak. He also discussed the numerous domes or laccoliths resembling shield volcanoes on Earth in diverse areas such as Mare Tanquillitatis (Sea of Tranquility), Mare Nubium (Sea of Clouds), and Oceanus Procellarum (Ocean of Storms). Ne notes the rough circular plateau Rumker rising to a height of half a mile in Procellarum and the hundreds of igneous intrusion domes. Paul Spudis presented a paper at the 2011 Lunar and Planetary Science conference making the case for shield volcanoes on the lunar surface! (6)

### **Geophysics**

Another interesting discussion in this chapter on page 106 is that of the theories of the origin of the Moon. He notes the publication “The Tides” by G. H. Darwin published in 1898 that hypothesized that the Moon was torn from the early melted Earth by tidal oscillation until “a great swell was torn from the plastic Earth and thrown into space. On page 110 he notes the radar findings of a 7,000 foot swell on the side of the Moon facing Earth. He states” If it proves to be a fossil tidal bulge, it means the Moon once was capable of adjusting its shape to the tidal pull of the Earth, and they were both formed together.” On page 91 he notes “The Earth pulls the surface of this little world 81 times harder than the Moon pulls the Earth. And the pull is irregular: greater at the perigee, weaker at the apogee, but is considerably more complex than that. The Sun adds its influence twice each month, when the Earth is full and again when it is a dim thread of silver in the lunar sky. When the Earth is either full or new and simultaneously in perigee, the land tides are unusually severe. At quarter phases of the Earth, the terrestrial pull is partially neutralized by the Sun and the tides are weaker at perigee and weaker still at apogee. Long ago, when the Moon was young, and perhaps even now, these powerful and constantly varying attractions of Earth and Sun could have created fractures, triggering eruptions and even volcanism.”

The recent discovery of water in the lunar interior and the anticipated results of the GRAIL mission, which should be launched this year should provide new insights to the scale of the lunar core and measurement of the density of the interior of the Moon and advance the understanding of lunar geophysics.

### **Technology Transfer**

Another prescient aspect of this book concerns a chapter on technology transfer. The “spinoffs” of Apollo are a frequent justification for NASA's budget and here again Ruzic leads the way. He mentions the development of “maraging” steels so called because their martensitic crystalline structure is age hardened..... These steels are almost completely carbon free and contain from 18% to 25% nickel as well as other alloying agents.” “These alloys, containing molybdenum, chromium, aluminum and of course nickel, were designed to withstand high heat and stress in spacecraft structural castings and as other panels of reentry vehicles.” I seems noteworthy that such steels may be comprised largely of in situ lunar material and an important work around the requirement for carbon as an important component of steel on the carbon deficient Moon. He also mentions the development of vacuum -aluminized polyester only .05 thousandth of an inch thick. which was used for the echo satellite and which was also used as an efficient super-insulator for extremely low temperatures. Similar material is now being used for solar sails. Pyrolytic Graphite was also developed as a material highly resistant to heat abrasion for missile cones and thermal shields.

### **Political Strategy As An Alternative to War**

Ruzic also has a considerable discussion of the Moon Program as a substitute for a war economy and psychology. This is clearly born of the temper of the cold ward competition between the US and the Soviet Union of his time and of the context of having witnessed two world wars in the first half of the twentieth century. It is also pertinent to our time where a permanent culture of war seems to pervade current US policy.

### **Astronomical Platform**

Ruzic also spends a chapter making the case for the Moon as a platform for observing the rest of the solar systems and the universe. In this instance his arguments have proved less prophetic since the development of the Hubble Telescope and the other orbiting Great Observatories and techniques for correcting atmospheric distortions by giant ground based telescopes.

### **BEM (Big Eyed Monsters)**

Ruzic also addresses the search for extraterrestrial intelligence in his rationale for the Moon. In this he did strike a cord and foresaw the rise of an Astrobiology focus on Mars as a significant multi-disciplinary endeavor. He does address four biologic reasons for lunar development:

- (1) As another world laboratory to study transplanted microbes, plants, animals and man.
- (2) As a sanatorium for the inform) who can afford it)
- (3) As a low gravity, no atmosphere base for more economical and more frequent unmanned or manned life-searching missions to Mars and the other planets;

- (4) As a farside base for the interception of radio or light signals from extra solar system intelligences.

He does mention the contributions of Frank Drake in computing the potential for discovering extraterrestrial intelligences and discussed the construction of Arecibo-scale radio telescopes on the lunar farside as a means to trying to communicate over a distance of 500 light years.

These suggestions now seem a bit quaint but the establishment of curation facilities on the Moon is still a matter of discussion for the analysis and sequestration of future astrobiological samples. While the prospects for the discovery of life on the Moon seem as remote today as then, the potential for bio-mining applications for in situ processing of lunar resources may well become practical and important.

A lunar “sanitarium” seems to be almost a Victorian conception of the cache of lunar tourism today. The Moon as an economic base for life=searching unmanned missions to Mars now seems very silly but the Moon's role as the nearest, cheapest test bed for many Mars relevant technologies is right on target.

#### Summary:

*The Case for Going to the Moon* is a very worthwhile volume 50 years ahead of its time in many predictions and one which remains a remarkable intellectual product by a brilliant author and technologist. Thanks again Ken Murphy for the gift of this generous and unusual book!

#### Notes:

- (1) Spudis and Lavoie: [www.spudislunarresources.com/Papers?Affordable\\_Lunar\\_Base.pdf](http://www.spudislunarresources.com/Papers?Affordable_Lunar_Base.pdf)
- (2) Jeff Greason: <http://www.nss.org/resources/library/videos/ISDC11greason.html>
- (3) Bienhof, Dallas: [http://spaceshowclassroom.files.wordpress.com/2010/09/100527\\_cislunar\\_isdc10\\_r2\\_novideo1.pdf](http://spaceshowclassroom.files.wordpress.com/2010/09/100527_cislunar_isdc10_r2_novideo1.pdf)
- (4) B. Kent Joosten, NASA Lyndon B. Johnson Space Center, Houston, Texas, and Lisa A Guerra, Science Applications International Corporation, Washington. D.C., “Early Lunar Resource Utilization: A Key to Human Exploration AIAA 93-4784.
- (5) Ken Murphy: <http://www.vimeo.com/24809886>
- (6) Spudis, Paul D., McGovern P.J., Keifer, W.S., 42 LPSC, Large Shield Volcanoes on the Moon # 1367.

#### Editor's Note:

Neil Ruzic was a member of the National Space Society's Board of Governors until he died of cancer in 2004; There was quite an article about him in **The Chicago Tribune** on the occasion of his passing:

[http://articles.chicagotribune.com/2004-01-23/news/0401230070\\_1\\_moon-base-lake-michigan-industrial-research](http://articles.chicagotribune.com/2004-01-23/news/0401230070_1_moon-base-lake-michigan-industrial-research)



## A Global View of A Space Settlement Policy

David Dunlop, Moon Society, July 12, 2011

### Background

If we look at Jeff Greason's space settlement strategy recommendations for NASA\* we might look as well as how these fit within a larger context of international space settlement strategy His speech and recommendations were put forth at the 2011 ISDC within the context of NASA's current and future constrained budget scenario.

[www.nss.org/resources/library/videos/ISDC11greason.html](http://www.nss.org/resources/library/videos/ISDC11greason.html)

Yet he developed a strategy that addressed these limitations and that lead to a set of **objectives and tactics that would lower the cost of going from one destination to others more distant.** With regard to **his strategy of going to destination where “gas” can be produced and island hopping in this fashion to ever more distant destinations,** we might ask why this advice, if good for NASA would not make just as much sense for the other space faring powers?

### Fuel

First, we should state that current NASA technology budget does reflect work on the storage and transfer of cryogenic propellants. To give credit where credit is due note the long term work of Dallas Bienhoff (1) and his group at Boeing in this regard have provided the trade studies Demonstrating the utility of this approach. In addition, the advice of Jeff Greason is remarkably similar to that of Paul Spudis\* and Tony Lavoie\* who has similarly proposed ice mining and fuel production as the appropriate and cost effective means of providing an affordable way of returning to the Moon and lowering the cost of cislunar operations through lunar based fuel production.(2) The Moon Society has presented it University of Luna award to these individuals as acknowledgment. It should also be noted that this strategy was expressed as early as 1965 by Neil Ruzic in his Book *The Case for Going to the Moon* (3), and also in the 1993 paper by B Kent Joosten and Lisa A Guerra, “Early Lunar Resource Utilization: A Key to Human Exploration” (4)

### Robotic “Villages”

Second, note that recent ILEWG conferences have presented an international lunar return strategy that has to do with precursor missions and the development of the “robotic village”. We have reported on these plans in earlier issues of M3IQ (5) for Japan, Russia, ESA, and China. Note that Russian plans in particular show on site fuel production. The development of a database for Surface Payloads and Advanced Concepts for Exploration is being undertaken by Dr. Pam Clark at NASA Goddard with collaboration at the Lunar Science Institute at NASA AMES. (6)

### Objectives

What are the objectives and best tactics to establish precursor robotic villages that lead to fuel production?

**A. The first step is the adoption of an international architecture that incorporates the use of orbital refueling stations in LEO and L1.**

The European architecture study conducted with NASA for a coordinated lunar return included an L1 refueling station and outpost. *Even if NASA develops this*

*technology it should be shared with international partners so that a refueling industry is created and a “standard” mechanism for storage and fuel transfer can be adapted so that all space faring nations are a collective market for its services.*

*NASA should open this technology development up to competitive contracting in a way similar to that provided for ISS access.*

This capacity will increase the ability of existing international launchers to get payloads to GEO, lunar, and translunar destinations.

**B. Characterize the lunar ice deposits and determine, which has the best potential for mining ice for the creation of rocket fuel.** (Based on mini-SAR from Chandrayaan I, and a similar instrument on LRO).

This will require additional surface survey missions. With the deletion of NASA surface missions from budget consideration these survey missions are not the province of the Chinese, Japanese, Europeans, Indians, and Russians plus potential GXLP teams if contracted for that purpose.

**C. Several sites have good potential in both the North and South lunar Polar Areas.**

(See Maps on Wet versus Dry Moon presentations on the LPI Site: <http://www.lpi.usra.edu/>).

Identify those sites with optimum characteristics for lunar ice mining based on the most recent lunar mission data. Utilize the limited number of sites (region) with a number of advantages including:

1. Ice deposits thought significant for potential mining
2. Proximity to extended illumination for solar power
3. Surface temperatures moderated by the oblique angle of solar incidence
4. Lunar Surface terrain that provides safe lunar landing sites with appropriate separation from potential habitation sites, and sites for robotic mining operations.
5. Lunar Topography that has surface slopes, which can be safely navigated by exploration and mining equipment. (This is critical for access to the areas of extended illumination and the potential deployment of solar collectors and energy transmission equipment.)
6. Surface regions of interest for broadening lunar geological exploration.

Surface maps that address these issues now define an ice and mineralogical exploration optimum footprint. The capability to operate within these footprints is a tactical matter of building up the robotic village(s) and appropriate surface infrastructure.

**D. Identify Technology Development Objectives for Lunar Ice Region Operations (6)**

1. Develop equipment, which can survive the surface temperature extremes in the mapped regions for several lunar cycles.
2. Demonstrate the creation and utilization of “thermal wadis” for rover and other equipment to increase the useful operational lifetime of landed equipment.

3. Demonstrate the operation of power transmission in the mapped regions.
  - Solar collector to laser power beaming
  - Solar collector to microwave power beaming
  - Solar collector to a potential SC cryo-cable transmission line, which could provide a provide a power recharge point for equipment in permanently shadowed areas.
4. Demonstrate the ability to retrieve surface deposits of ice and to process them for the extraction of volatiles.
5. Demonstrate the ability to transfer extracted volatiles to landed tanks for storage, separation, and subsequent storage and transfer.
6. Demonstrate the ability of equipment to conduct volatiles surveys on lunar regolith to accurately characterize the volatile contents on a repetitive basis and to identify “tagged” volatiles of human origin from those that are natural to the site.
7. Demonstrate the ability to provide in situ curation of collected lunar samples for subsequent collection and transportation.
8. Demonstrate the ability to utilize microwave equipment to sinter surface regolith and liberate frozen volatiles from a matrix of frozen volatiles and regolith materials

**E. Define the smallest instrument/lander package that can accomplish the ice survey objectives.**

**F. Similarly create equipment, which can achieve the engineering Demonstrates and determine if both national space agencies and the GLXP teams landers can serve as the platforms for the delivery of these instruments.**

*By common agreement these ice mining survey payloads would be carried as the first priority payload for the next round of lunar surface lander missions.*

**G. Develop international agreements** for “complementary missions” targeting and data sharing a series of ice mining & prospecting missions in the limited number of optimum locations for ice mining.

**H. An International Space (Lunar) Development Authority Corporation** would provide a neutral international mechanism for a multi-national initiative to identify and establish the best locations for ice mining potential and for the build up of robotic village capabilities. This corporation would provide a mechanism for development without the de facto risk of national competition/claims on these scarce high value areas. Development of such regions by investors would need their investments recognized and protected by these legal mechanisms with subsequent commercial access to ISRU resources based on based on a largely transparent investments and equitable prices of products.

**Practical Suggestions**

These sites could be targeted by the international space faring community with missions already under consideration and development.

**Table 1: Lunar surface Missions in Recent Planning and Development at Present:**

1. Moon Next                    ESA 2018                    (South Pole Aitken Basin)
2. Selene II                    JAXA 2018
3. Lunar Resurs with Chandrayaan II 2014 or 2015  
ISRO & Roscosmos
4. Lunar Grunt`                Roscosmos 2014?
5. Chang'e III & IV?        CNSA 2013, 14-2015?
6. South Pole Aitken Basin Sample return  
(lost New Horizons competition)
7. ILN Missions                (Budget deleted in 2012 may be eligible for New Horizons competition in early 2020s)

**Potential Google Lunar X-Prize Team NASA purchases A Next Stage COTS lunar access contract process.**

8. NASA could **purchase payload delivery** from eligible US teams GLXP teams using a Commercial Launchers such as Space-X Falcon 9 and incentives from Space Florida. This might be competed in the same way that the ISS supply missions are being developed. GXLP Teams would be selected in a purchase qualifying process based on techno-logical feasibility, cost, schedule, and innovation.

Those teams eligible for participation would have to show that their own capital development, technical development, and technological feasibility justify public investments via contracts, and demonstrate that they are also cost competitive with NASA internal cost proposals. This competition would likely lead to some consolidation of team efforts and the elimination of teams lacking sufficient resources and technology development. The GLXP has indicated that initially it did not expect team entrant to exceed single digits worldwide. With some 29 teams at the close of team registration in February of 2011 there is now an embarrassment of riches.

A next stage Lunar COTS access contract process makes sense to further advance our ability to access the lunar surface for this initial survey of ice mining potential. Astrobotic 2014? \$150M Estimated mission cost \$1.5M per kg delivered to lunar surface.

- Moon Express                \$?
- Next Giant Leap            \$?
- Other US teams             \$?

A number of additional questions need to be answered about this introduction of contracted lunar access:

- What is the potential cost to NASA to use these contract GLXP missions?
- What budget resources could be marshaled in the upcoming NASA budgets to support these purchase missions given the projected reduction of the Lunar Quest line item?

There is at least one publicly identified price point of \$1.5M per kg of payload delivered to the lunar surface from GLXP Team Astrobotics. This is for first-time missions in the context of the GLXP. What can be done to further lower this price point? Would this cost be reduced in subsequent lunar surface missions in the context of a commercial purchase paradigm?

What is the ratio of NASA dollars to private investment dollars in these missions? Initially the GLXP rules indicated that no more than 10% of these teams' costs could be government-derived. Is there some realistic ratio of public/private investment that should be required for a commercial paradigm? This ratio in part depends on what non-government partners actually exist in the market place. The impact of NASA's ESMD Innovative Lunar Data Demonstrations \$30M on those US teams eligible for these funds is unclear to this writer as their financial information is proprietary. Hopefully both SMD and ESMD can extend this approach given the financial constraints as these mission price points are well below the norms for NASA Discovery Class Missions.

*We might also hope that other non-US GLXP teams (not eligible for NASA contracts) might similarly benefit from purchase programs by their national space agencies.* What additional possibilities might exist if contracting with GLXP teams were supported by other national space agencies?

**7. What about other non-US GLXP team vendors?**

What about team **Odyssey Moon** for example? Where potentially could Odyssey Moon get purchase contracts?

**A Commonwealth Purchase Initiative:** Might a consortium of Commonwealth countries finance this mission as below?

	<b>Commonwealth Member</b>	<b>Space Agency</b>
A	Australia	CSIRO (Lunar Numbat)
B	Canada	CSA (Plan B)
C	India	ISRO Potential Supply of the launcher with costs shared by other Commonwealth partners) (India has its own GLXP team registered – Team Indus)
D	Isle of Mann	(UK) Odyssey Moon
E	Malaysia	ANGKASA
F	New Zealand	(Lunar Numbat)
G	Nigeria	NASRDA (Nigerian National Space Development Agency)
H	Singapore	A*STAR Agency for Science Technology and Research
I	South Africa	SANSA
J	UK	UKSA Surrey Satellite

**8. What potential is there for GLXP lunar instrument delivery purchases from ESA in a program (similar to NASA) and with the support of other European Space Agencies:** (A non-inclusive GLXP list follows):

Austria	ALR	
Belgian	BISA	
Denmark	DNCS	
Germany	DLR	Part-time Scientists
France	CNES	
Hungary	HSO	Team Puli
Italy	ASI	Team Italia



France	CNES	(ISU)
Netherlands	SRON	White Label Space
Poland	SRC	
Romania	ROSA	ARCO
Spain	INTA	Team Barcelona
Switzerland	SSO	Swiss Propulsion Lab

**9. What potential is there for GLXP team purchases from other nations?** The following countries also have GLXP teams:

Chile	ACE
Brazil	AEB
India	ISRO
Japan	JAXA
Russia	Roscosmos

**10. What potential is there for GLXP team purchases from a consortium purchases with many international and commercial participants.**

I think that the purchase precedents that have been set by NASA are a positive direction, which I hope will translate into similar policies by other space faring nations and their national space agencies. This orientation would greatly boost the feasibility of a commercial cislunar and circumlunar space industry.

**Footnotes:**

1. Jeff Greason ISDC 2011 Speech, <http://www.nss.org/resources/library/videos/ISDC11greason.html>
2. Paul Spudis\* and Tony Lavoie\* [www.spudislunarresources.com/Papers?Affordable\\_Lunar\\_Base.pdf](http://www.spudislunarresources.com/Papers?Affordable_Lunar_Base.pdf)
3. Neil Ruzic, The Case for Going to the Moon, Putnam, 1965 [See Book Review above]
4. B. Kent Joosten, NASA Lyndon B. Johnson Space Center, Houston, Texas, and Lisa A Guerra, Science Applications International Corporation, Washington, D.C., "Early Lunar Resource Utilization: A Key to Human Exploration AIAA 93-4784.
5. Moon Miners' Manifesto – India Quarterly #9, pages 21 and 22, download from: [www.moonsociety.org/india/mmm-india/](http://www.moonsociety.org/india/mmm-india/)
6. Clark, P.E., Dunlop D, SPACE LIST (Surface Payloads and Advanced Concepts for Exploration) Open Access Data Base/Spreadsheet Tool and Working Group (#1112) 42<sup>nd</sup> LPSC Program, Thursday Poster Sessions (# 1112)

This list is in development by Dr. Pamela Clark at Goddard SFC.

\* The Moon Society has presented its University of Luna Award to these two individuals as acknowledgment of their strategic contribution toward space settlement and the development of the Moon.

For a list of previous U. of L. awards, go to: <http://www.moonsociety.org/about/awards/>



## Mapping a New Era of Lunar Exploration and Development

By David Dunlop  
July 13, 2011

The data sets that are being provided from the last round of lunar satellites missions are laying a foundation for the mapping of the next rounds of lunar exploration and the development of human enterprise(s) on the lunar surface. They are also constraining our views of how this might be most effectively done.

### 1. Water

First, the dominant change in the view of the Moon is that concerning the location and abundance of water, particularly of ice in the Polar Regions. The post Apollo view of the formation of the Moon as the result of a collision of a "Mars-sized" object with the Earth was one of extreme desiccation of materials in a disk surrounding the Earth in the vacuum of space. Without water on the Moon the cost of bringing fuel and life support supplies has been the showstopper cost barrier to post Apollo human presence on the lunar surface.

This model is now being reworked as new additional evidence of water on the Moon is being reported.

The Chandrayaan I and LRO missions have identified strong evidence of large amounts of water in the Polar Regions. Several strands of evidence from several instruments and spacecraft are consistent with this conclusion.

**From several threads of evidence:**

- Chandrayaan-1 impactor
- Chandrayaan-1 Mini Sar
- Sar on LRO
- LCROSS
- LEND instrument neutron spectrometer

Correct interpretation of water abundances is a complex process (1). The circular polarization ratio of synthetic aperture radar instruments suggest significant ice deposits in permanently shaded crater at both the north and south poles. (2) This distribution of water on the Moon shows amazing geologic diversity. (3) (4).

### II. Temperature

Water however is not the only surprise in these new data sets. The Diviner Instrument on LRO also has provided new **temperature information**, which makes the Moon the nearest location of the cryo-frontier! It contains perhaps the lowest temperatures known in the solar system in its permanently shaded regions, its "cold traps." (5) These temperature maps however also reveal in detail the more moderate temperatures in the illuminated Polar Regions. "Diviner has obtained sufficient spatial and temporal coverage to determine annual minimum, maximum, and average surface temperatures at both poles." Large areas of the lunar Polar Regions are currently cold enough to cold-trap water ice as well as a range of both more volatile and less volatile species. " (6) These temperature maps provide a better measure of the engineering challenges in these polar regions.

### III. Potential Landing sites

The LRO narrow field camera coverage from LRO has provided half-meter resolution imagery for a beginning set of 50 potential landing sites of interest during its first year of operation for the Exploration Systems Mission Directorate. Additional sites will be examined during the remaining mission under the Science Mission Directorate.

### IV. Lunar Topography

Topographical information is also developed in by the Lunar Orbiter Laser Altimeter (LOLA) instrument on LRO based on more than 3.4 billion altimetric measurements. More than 68.8% of the Lunar North Pole has been mapped and 67.6% of the South pole and these ratios will continue to improve at the mission continues. (7) LOLA has identified some 3660 square km of permanently shadowed regions poleward of 87.5° in the North Polar area and 2751 square km of permanently shadowed regions poleward of 87.5° in the South Polar Area. (7)

Detailed elevation maps can now identify with more precision potential surface routes for exploration vehicles and robotic systems.

### V. Extended Solar Illumination

A Detailed characterization of illumination conditions has been made in both the north and south lunar Polar Regions from Lunar Reconnaissance Orbiter Camera based on over 11,000 Wide Angle Camera images and 6,500 Narrow Camera image pairs within 2 degrees of the poles. These have been reduced to illumination maps, movie sequences, and high-resolution maps to delimit lightning conditions over one year. (8) “These products reveal a region near the South Pole that remains illuminated for a majority of the year (92% of the year, a 10% increase over some previous studies).” “We have located a 2.25 square km region (centered at 89.4° south, 223 degree E that remains illuminated 92% of the year. “ Previous studies have identified peaks around the South Pole that remain illuminated for a majority of the year, including a massif (Point B) located -10 km off the edge of Shackleton crater that is estimated to be illuminated for 82% of the year (9)

“During summer months the NAC acquire 100s of images that are used to create meter scale maps of the illuminated terrain at the South Pole.” Spudis and Bussey report, “ two locations close to the rim of Shackleton were collectively almost permanently illuminated.” (10) “Key results for the North Pole include identification of places near the rim of Peary that were illuminated for an entire summer day, as well as locations of permanently shadowed crater on the floor of Peary crater. “JAXA’s Kaguya spacecraft returned the first laser derived topographic data of sufficient fidelity to be useful for illumination studies. ....”The Kaguya data can be used to generate precise lighting predictions.”

“One aspect we are studying is the needed height of a mast to reduce the duration of shadowed periods.” “Regions that receive near -constant solar illumination are possible sites for future lunar bases. Not only do these areas permit operations in a relatively benign thermal environment, but also a lunar base could be supported by solar

photovoltaics without the need of additional power sources.” (10)

“Some areas near the poles (are) in permanent shadow, while other nearby regions remain sunlit for the majority of the year. Previous studies ..... have delimited these regions.. (and) observations suggest that volatiles may be present in cold traps in permanently shadowed regions. /thus areas of near permanent illumination are prime locations for future lunar outposts due to their benign thermal conditions and near constant access to solar power. (8)

### VI. Scientific Exploration and Sampling

The Moon Mineralogy Mapper on Chandrayaan-1 has provided unprecedented information on the geochemical composition of the lunar surface so the location of different geochemical terrain can be determined for future mission planning and ISRU utilization. Both Polar Regions differ from the terrain sampled from the Apollo Mission.

### VII. Optimal Exploration Footprints”

**A. “optimum exploration footprints”** - In combination, these new maps/data sets let us identify the most promising areas for ice mining and associated on site [ISRU] fuel production, the capture of other volatiles from cold traps and other associated operations for a lunar research and fuel production base. These footprints will be more limited than some of those identified for a much broader range of lunar exploration scientific objectives. Nonetheless these ice-mining footprints will also expand the suite of lunar samples for and lead to a mature surface exploration capacity over time well beyond these initial “footprints of interest.”

There are a wide variety of sortie missions that can be enabled in a second stage of lunar exploration after the infrastructure for ice mining and fuel production has been established and lunar ferry systems established to an L1 and lunar surface locations. These include many new targets such as:

- Lunar Lava tube skylight openings
- New Pyroclastic deposits and the discovery of volcanic vents
- Farside lunar mare areas that may contain exposed mantle material
- KREEP deposits
- Other volcanic features such as domes, and rilles.

**B. The strategy of establishing lunar robotic villages** will include a variety of tactics that will vary with participating national technological expertise, scientific interests, financial resources, and educational priorities. These tactics can deal with a range of issues:

- A successive build up of robotic resources and capabilities
- Power and water proximity
- ISRU equipment for fuel production and storage: a major strategic enabling objective
- Sustainability of equipment on lunar surface
  - # Extended use for lander systems in robotic village.
  - # Ferry/Landers that are more than single use expendable vehicles.

- Development of Tank Farms
  - 1 Water:
  - 2 Oxygen Production
    - # for Life support
    - # as Fuel component
  - 3 Hydrogen Production
  - 4 Separation of storage of non -water volatiles such as CO, CO<sub>2</sub>, N, and other constituents identified by LCROSS impact splashout sampling.
  - 5 Power Production
    - # Thermal Wadi
    - # Solar PVC
  - 6 Surface Mobility
    - # local base
    - # robotic traverse support
    - # human traverse
    - # human hopper missions
  - 7 Surface Habitation & Labs
  - 8 Establish a Lunar surface ferry system

### III. Terrestrial Industrial base capabilities:

- Parallel development of redundant supply chain capabilities internationally:
- New launcher development:
- New Technological systems:
  - # Orbital Fuel Storage, Transfer and Refueling capabilities
    - LEO
    - L1
    - Lunar Surface
    - Cislunar Tugs
    - Solar Electric Propulsion

### IV. The Legal Structure of Participation for Scarce Resources and Limited Areas for exploration:

**The understanding that there are a limited number of optimal exploration areas for the beginning of ice mining and fuel production on the Moon presents a practical test of the Outer Space Treaty involving any national territorial claims.**

Those that come first and establish a productive presence have by many precedents some operational claim to their developed terrain. In the harsh climate of the lunar surface human presence is difficult and expensive to maintain under the best of circumstances. These exploration “sweet spots” are a scarce and valuable commodity on the immense globe of lunar terrain.

A Legal framework for mutual investment, use of common essential services and equipment, and the ability, right, and obligation to sell products from “common heritage” lunar resources to the “at large” human community is essential. As a practical matter there are benefits to share costs, share risks, and “divide profits.” We have an early example of enabling such mutuality of interests with the precedent of the ComSat Corporation in the early 1960’s.

An International Space Development Corporation has been suggested and created as a mechanism for such development by Declan O’Donnell of United Societies in Space, an NSS affiliate organization. This ISDAC Structure is an early strategic mechanism, which could provide for an open participation and open investment model, market development, and the development and provision of enabling strategic requirements such as:

- Fuel Depots
- A redundant supply chain with multiple launch systems and providers
- Space Tugs for pushing a supply chain out to L1 and the lunar surface.
- Construction capabilities at early destinations such as LEO, GEO, L1, Lunar surface.
- An ISRU focus for commercial development of local resources.
- Shared habitation systems for international utilization.

### Summary:

New maps of lunar terrain indicate the limited locations for optimized lunar bases and operations. These regions now define the prime locations for the next steps in lunar development.

### References:

1. Jean-Philippe Combe, Thomas B. McCord, Paul O. Hayne, <http://www.lpi.usra.edu/meetings/volatiles2011/presentations/Combe.pdf>
2. Mini-rf evidence for water ice at the poles of the Moon, P. D. Spudis, D.B. J. Bussey, LPI Contribution 1621, # 6017.
3. Mapping Water and Hydroxyl on the Moon as seen by the Moon Mineralogy Mapper, Roger N. Clark, Carle Pieters. et al. LPI Contribution 1621, p &
4. Clark R., (2009) Science 326, 562-564.
5. Diviner Lunar Radiometer Observation of the North and South Polar Regions, D.A. Paige, M.A Sieglar, and J.P. Williams, LPI Contribution 1621, p44, (#6058).
6. Paige, D. A. et. al. (2010) Science, 330, 463.
7. Illumination Conditions of the Lunar Poles From Lunar Orbiter Laser Altimeter Data, E. Mazarico, G.A. Neumann, D.E. Smith, M. T. Zuber, and M.H Torrance, LPI Contribution No 1621, p 37, # 6007.
8. Analysis of Highly Illuminated Zone Near the Lunar Poles, E. J. Speyerer, and M.S. Robinson, LPI Contribution No 1621, p. 60, (6054).
9. Bussey et. al. (2003) GRL, 30, 1278.
10. A Review of Lunar Polar Illumination Studies Using Clementine, SMART-1, Kaguya, and LRO Data, D.B. Bussey, P.D. Spudis. LPI contribution No. 121, p 5. (#6038).



## Astrobiologists Discover Strange Benthic Microbial Mats in Lake Untersee Just SE of India's Antarctic Station Maitri

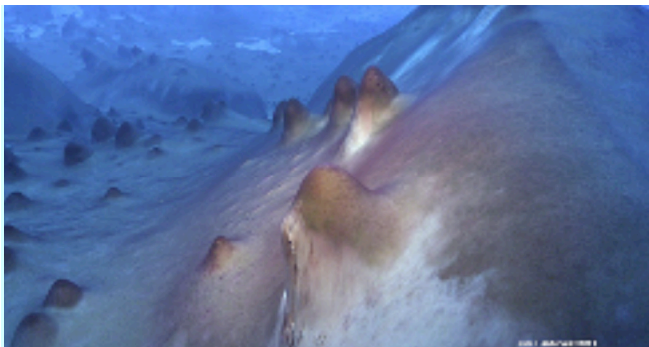

Report by Peter Kokh

Sources: <http://www.onorbit.com/node/3221>  
[http://en.wikipedia.org/wiki/Lake\\_Untersee](http://en.wikipedia.org/wiki/Lake_Untersee)

“In the eerie bluish-purple depths of an Antarctic lake, scientists have discovered otherworldly **mounds** that tell tales of the planet's early days. **Bacteria slowly built the mounds, known as stromatolites, layer by layer on the lake bottom.** The lumps, which look like oversized traffic cones, *resemble similar structures that first appeared billions of years ago and remain in fossil form as one of the oldest widespread records of ancient life.*”

These purple mounds are as much as a half-meter (20”) high, and though composed of microscopic bacteria, are collectively quite macroscopic, of a size to which we can relate by naked eye. This type of life may date back as far as 3 billion years. In comparison, multicellular life large enough to be easily visible to humans as “plants and animals” evolved less than 600 million years ago.

Stromatolites now actively form in a few areas of the ocean: off Australia's west coast and in the Bahamas. They are also found in ultra-salty lakes in the high Andes and in a few other freshwater lakes in Antarctica. But nothing like the size and shape of Untersee's large mounds had been discovered to date.

Exobiologists had first been attracted to Lake Untersee, not suspecting what they would find, by the lake's extremely alkaline waters and high amounts of dissolved methane. These unusual and exotic mounds “studded the lake's bottom like barnacles clinging to a ship hull. ”



Diver entering Lake Untersee

### Slow Growth, *very slow!*

Samples taken of one of the mounds showed it to be composed “**mostly of long, stringy cyanobacteria, ancient photosynthetic organisms.**” The bacteria may take decades to build each layer in the ice-cold water. The mounds may have taken thousands of years to build up to their present size.

It was clear to the scientists investigating that there had to be something unique about Lake Untersee itself. The thickness of the lake's ice crust and its degree of translucency, as well as the gases and minerals dissolved in the water vary from lake to lake in Antarctica. Lake Untersee must have that special mix.



Above, Below: views of Lake Untersee from the air



### About Lake Untersee (from Wikipedia article)

- Location:** 90 kilometres (56 mi) to the southwest of the Schirmacher ice-free Oasis on which Maitri sits.
- Size:** 6.5 x 2.5 km (4.0x1.6 mi)
- Surface area** 11.4 square kilometers (4.4 sq mi)
- Max. depth** 169 meters (554 ft)
- Surface elevation** 563 metres (1,847 ft)

### Lake Untersee and Exo-Life beyond Earth

We have no idea what we might find in Europa's global ocean, which has more volume than Earth's ocean, or under the crust of Saturn's moon Enceladus. Nor do we have an idea of what we may find in Titan's liquid methane lakes. But Lake Untersee certainly primes the imagination.

Indian scientists from Maitri could easily make the short trek to this lake and do some exploring of their own. For exobiologists, Lake Untersee is a preview of heaven or nirvana! ▣

## ANALOG RESEARCH NEWS

### The International Space Station as an Analog for Mars Missions

Report and Commentary by Peter Kokh

#### *Can ISS be used to advance the goal of sending humans to Mars?*

That was the question that a new conference, “ISS and Mars”, held in Washington DC US April 6-7, 2011 sought to address. Topics discussed included human factors, technology development for beyond LEO, the use of ISS for mission analog projects, commercial participation, and whether the ISS international partnership model can be used for missions beyond LEO - specifically Mars

The conference was held at George Washington University and sponsored by [ExploreMars.org](http://ExploreMars.org) and by the **National Space Society**.

#### Background

The International Space Station in this context can be seen as a model of a large spaceship en route to Mars. The big difference, of course, is that ISS is dependent on continuing shipments of water and oxygen and food. While those who first proposed a Space Station insisted that it have a high priority goal of becoming “biological life-support independent,” NASA never pursued this goal in earnest. *Resupply from Earth was too easy!* The risk of astronauts on board being cut off from resupply for long periods was dismissed as unlikely, in a high stakes gamble. It was all about “the budget” not about “the goals.”

The same criticism would apply in trying to sketch an analogy between ISS and an early outpost on Mars. But the stakes here are even higher. Whereas supplies to ISS can be sent at almost any time, launch windows to Mars occur a challenging 25.5 months apart. A human base on Mars would absolutely need a cache of supplies, both food and parts, that could last that long and to be safe, much longer!

In an article in Moon Miners’ Manifesto #113 March 1998, page 6: YOLK SAC LOGISTICS, Strategy Tailored for Mars, we made the distinction between the umbilical cord approach which works for ISS and the Moon, and the “Yolk Sac” approach which alone could work for Mars. You will find this article in MMM Classics #12, pages 19-21 [Do read the following article as well: “Pantry Stocking: the role of “creative smuggling” in the Building of Marsport” The MMM Classics pdf files can be freely downloaded from: [www.moonsociety.org/publications/mmm\\_classics/](http://www.moonsociety.org/publications/mmm_classics/)

#### ISS & Mars Conference Report

Nonetheless, those presenting papers at this conference did take the matter seriously, and some interesting concepts and proposals came out of the process. And for this we give credit to [ExploreMars.org](http://ExploreMars.org) President Artemis Westinberg and Executive Director Chris Carberry, both of whom I have the privilege of knowing. The conference was a major step forward in that instead of leaving the opening of Mars to the distant future, this conference was about **identifying what we can do now, with what we have now**

(ISS) to advance the development of technologies needed for Mars missions whenever they can be budgeted.

#### NASA’s view of ISS as a simulated Mars Mission

<http://science.slashdot.org/story/11/04/22/189202/The-Space-Station-As-a-Simulated-Mars-Mission>

NASA is planning a week-long simulation of ISS as a “testbed” for a mission to Mars, in summer 2012. “Preliminary tests would involve working on **systems that give astronauts more autonomy**, perhaps culminating in a full mission analog, **sealing a crew inside a separate module of the station with minimal interaction with the rest of the station and mission control**. ‘We want to use the space station as a way to get smarter about what a mission to Mars or a mission to an asteroid might look like,’ space station.” But no word about simulating sealed life support systems. The agency is apparently not *that* serious.

#### ISS & Mars Missions as International Partnerships

Certainly, the idea of “Opening Mars” as an “International Partnership” effort on the model of ISS is not only valid, it is essential. International commitments are much less vulnerable to national budget-cutting mischief than are purely national ones. It cannot be just NASA, or just ESA, or just ISRO, JAXA, CNSA, or Roscosmos that sends a crew to Mars! We must go together or failure to stay the course is certain. Let’s leave “boundaries” back here on Earth. This is not the kind of “baggage” we need to take out into the Solar System.

International cooperation on the frontier has many precedents. On Earth, we have major international collaboration in Antarctica. In space we have seen these milestones:

- Apollo-Soyuz 7/75
- NASA Shuttle Mission to Russia’s Mir 1994-98
- International Space Station construction and manning: Hardware Contributions and International Crews
- 6 vehicles from 4 nations were docked at ISS Terminals for 2 weeks this past year □

### International Lunar Research Park Proposed for Hawaii Island

Report by David Heck, Moon Society, Boeing-St. Louis

**The Moon Society’s Dave Heck** reports on the efforts of the **Pacific International Space Center for Exploration Systems (PISCES)** at the University of Hawaii-Hilo. Research is being done by NASA, JAXA, ESA and CSA (Canada) in the lava fields on the slopes of **Mauna Kea**, land very similar to the lunar maria. **The intent is to evolve an International Lunar Research Park (ILRP) here on Earth as a prototype for such an outpost on the Moon.**

Dave met Professor Schowengerdt of PISCES at the NASA International Lunar Research Park Workshop earlier this year. Dave represented Boeing at the workshop and talked about his participating in Boeing’s research and development being done at the Advanced Manufacturing Research Centre (AMRC) at the Univ of Sheffield, England. The following video from the 2010 season gives an idea about some directions of current research at the site:

<http://www.bigislandvideonews.com/2010/02/05/video-hawaiis-lunar-like-mauna-kea-hosts-space-tests/>

## Exploring the Many Possibilities of Hybrid Rigid-Inflatable Structures

By Peter Kokh

### Introduction

When most people hear about inflatable structures for space, they think of the work of Bigelow Aerospace, a commercial enterprise headquartered in North Las Vegas, Nevada, US. Those of us who have been around a bit longer remember the work of NASA's TransHab project pursued in Houston. Thus of us older still, remember the pioneering proposals by Llowel Wood.

But "Inflatable Structures" is only one half of this wide-open field of Aerospace Architecture. There is another half, the perhaps more practical options offered by various "Hybrid Rigid-Inflatable" designs. The advantages are easier outfitting of the inflated section and pre-attachment to a rigid base unit.

This year, NASA's X-Hab Competition (this is year 2) is focused on designs for an "Inflatable loft" to a rigid one-story vertical hab. Take the familiar Mars Society's analog research station "habs", FMARS on Houghton Island in northern Canada, and MDRS in south central Utah. Remove the upper floor, and replace it with an inflatable unit. Lighter weight and more compact for shipment (to Mars, or to the Moon) are the happy result.

The considerable advantages include flexible dimensions. There is no reason why the upper inflatable annex cannot be of larger diameter, or even contain a third floor, while still weighing less and being more compact for shipping than a conventional rigid 2-floor vertical hab design.

We do not know if the Mars Society is following this competition with interest, but it certainly catches the attention of the Moon Society and of the editors of MMM and of the MMM-India Quarterly.

The current challenge is to design "an inflatable loft" to be attached to the top ring of the one-floor rigid hab module depicted below.



NASA X-HAB inflatable loft competition: Loft to be attached to top ring of hab structure above  
<http://www.spacegrant.org/xhab/2011>

### Introduction to the NASA Competition

"The Habitat Demonstration Unit (HDU) project will offer multiple X-Hab awards of \$5K - \$45K each to design and produce functional products of interest to the HDU project as proposed by university teams according to their interests and expertise. The prototypes produced by the university teams will be integrated onto an existing NASA built operational habitat prototype."

### Synopsis

"The X-Hab Academic Innovation Competition is a university level competition designed to engage and retain students in Science, Technology, Engineering and Math (STEM) disciplines. NASA will directly benefit from the competition by sponsoring the development of innovative habitat inflatable loft concepts from universities which may result in innovative ideas and solutions that could be applied to exploration habitats. The challenge is for a senior and/or graduate level design course in which students will design, manufacture, assemble, and test an inflatable loft that will be integrated onto an existing NASA built operational hard shell prototype [see photo bottom of column A].

"In June of 2011 the NASA-Habitat Demonstration Unit (HDU) Project will conduct a head-to-head competition for successfully designing and demonstrating an attachable inflatable habitat "Loft" (2nd level attachable) concept given a list of requirements for the design.

"Universities may collaborate together on a Project Team. Up to three project teams will be selected for funding. The head-to-head competition will determine the winner that will be awarded additional funds to integrate their design with the HDU-Lab during the August- September 2011 HDU-Hab/Lab integrated field testing.

"The objectives of this challenge are to engage and inspire the next generation of innovative engineers and the successful design, manufacture, and demonstration of inflatable habitat loft. Concepts are to be self-deploying in a specified time, will install to a standard interface on NASA's hard shell Lab (figure 2), and will meet total mass and volume constraints in both stowed and deployed configurations. Concept shapes and sizes will be determined by the proposer while meeting the constraints of the design requirements."

**Contenders:** Currently three universities are competing in this round: (1) Oklahoma State University; (2) University of Maryland; and (3) University of Wisconsin. All three have been in a yearlong design, build, and test curriculum that produced this product."

### Editor's Comment:

Hybrid hard-hull/inflatable designs are something **Moon Miners' Manifesto** has been promoting for two decades: At the 1991 International Space Development Conference held in San Antonio, Texas, US that year, the Lunar Reclamation Society (Milwaukee, Wisconsin chapter of the National Space Society) presented the following paper:

**The Lunar Hostel: An Alternate Concept for First Beachhead and Secondary Outposts, ©1991**

This paper, SDC-91-021 was published in the conference proceedings, pages 75-92, published by Univelt Publishers, San Diego, CA – ISBN 0-912183-05-5, 1991

On topic is the section

**Part IV. Possible Architectures appropriate for hostels:  
(4) inflatable hybrids:**

[http://www.moonsociety.org/publications/mmm\\_papers/hostels\\_paper2.htm](http://www.moonsociety.org/publications/mmm_papers/hostels_paper2.htm)

**Figure 4 The “Sandwich”**

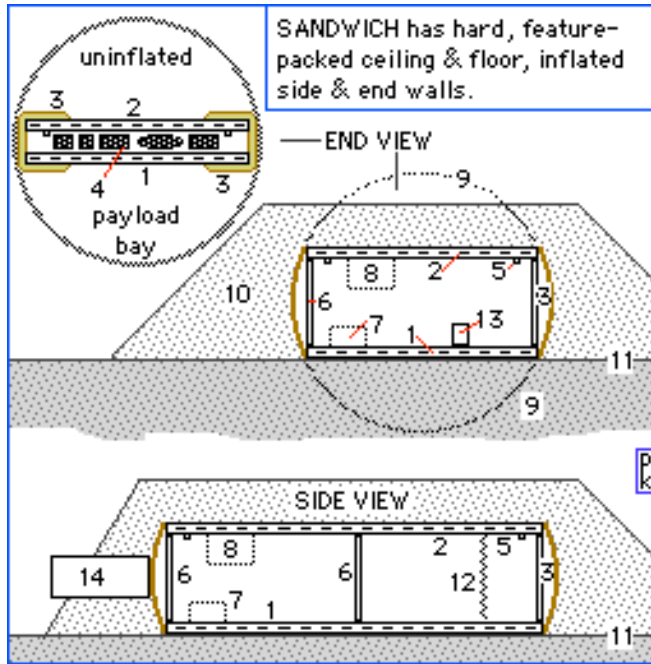

- 1] Floor module with pop-up built-ins.
- 2] Ceiling module with pull-down units.
- 3] Inflatable side walls and end walls.

**Figure 5 The “Slinky”** [popular children’s toy – image ↓]



our “slinky”, below

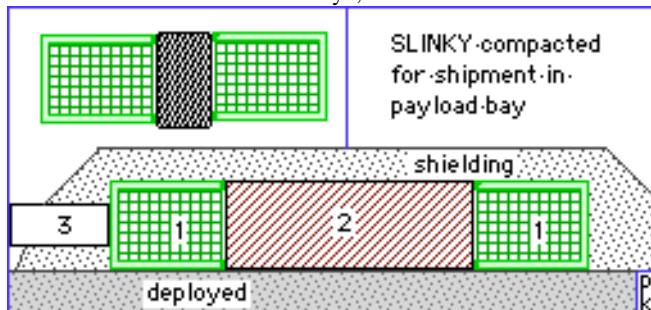

- [1] Pair of rigid end caps, with build-in equipment.
- [2] expandable slinky module (unfurnished).
- [3] docking tunnel.

**Figure 6. The “Quonset”**

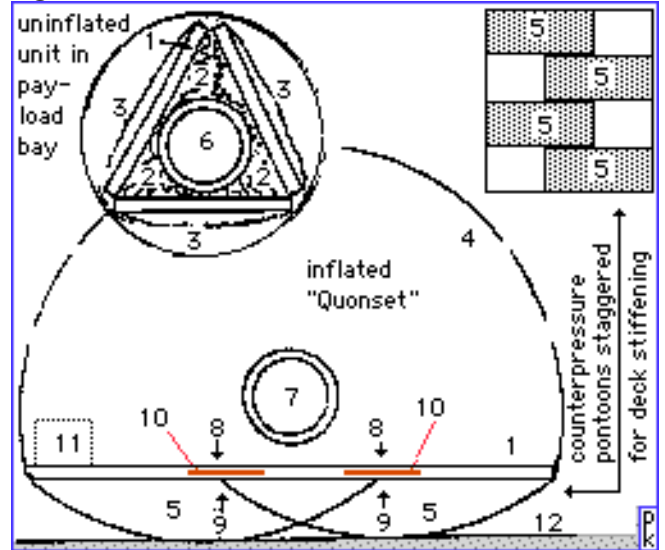

- [1] Hinged 3-section floor deck.
- [2] Uninflated quonset roof/wall
- [3] Uninflated floor support pontoons
- [4] Inflated quonset roof/wall
- [5] Inflated floor support pontoons
- [6] In transit position of docking module
- [7] Docking tunnel in end wall
- [8] Downward air pressure on hinges
- [9] Counterbalance pressure on hinges
- [10] Contingency stiffening bars
- [11] Representative pull-up feature
- [12] Ground contour before shielding

**Figure 7: The Donut:**

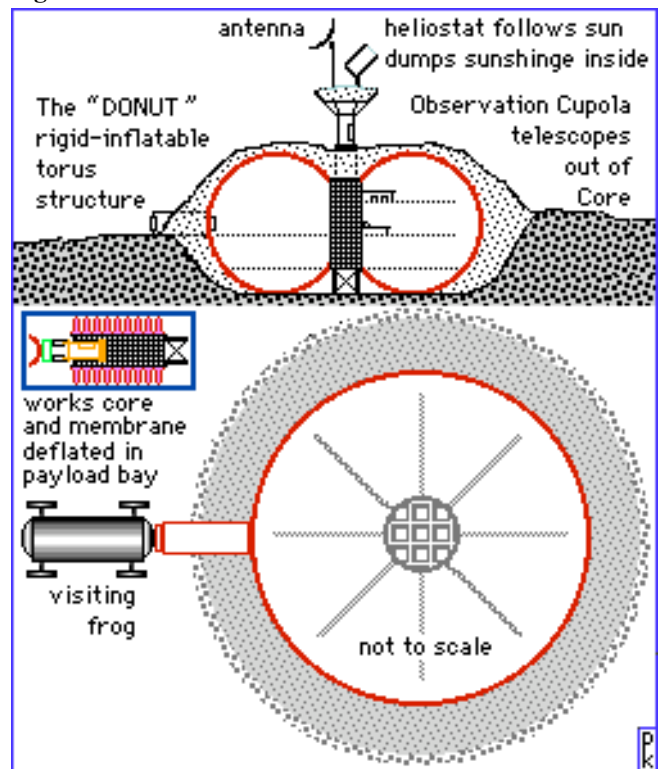

This 3-floor model is an upgrade of the simpler design in the original paper. **Shown is the central works-packed core, optional telescoping observation & EVA tower, antenna, heliostat.** Docking tube is at left. In this version, a small crater was chosen to make shielding easier and to allow the frog access to the middle level. Center left: a crude sketch of how the package arrives deflated in a payload bay, and a view of the donut hostel and docked frog from above.

**Figure 8: The “Trilobite”:**

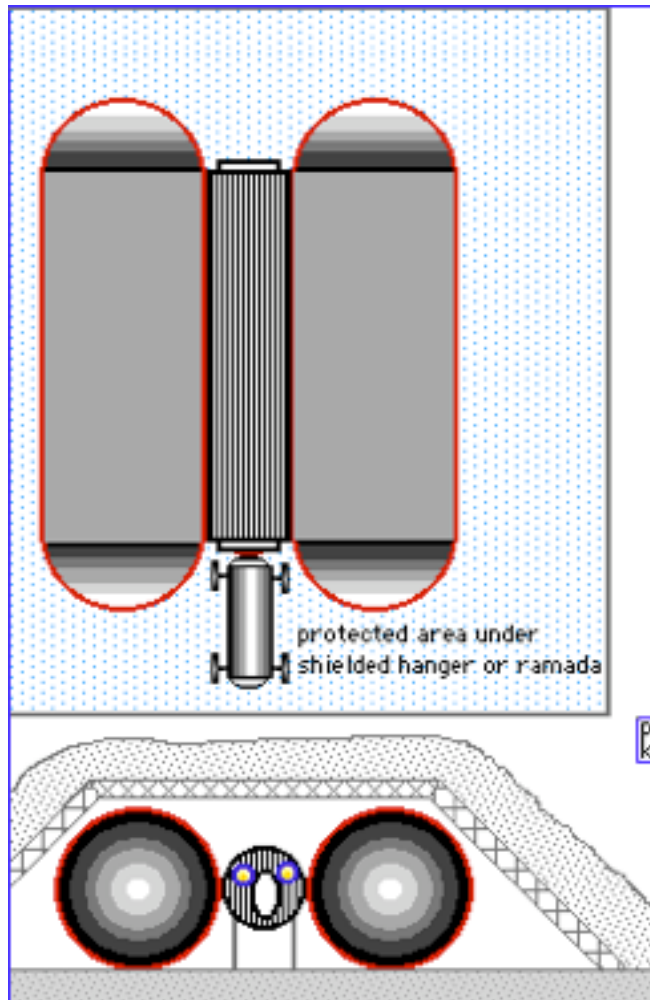

The works core module could be scaled to a 15' wide shuttle payload bay or to a 27' wide faring atop an External Tank, with inflatable cylinders proportionately sized. Here, the trilobite hostel sits under a shielded hanger, making servicing and expansion much easier.

In our paper we attempted to show a variety of directions in which hybrid rigid-inflatable space habitat architecture could go, without attempting to be complete.

**Continuing this line of thought:**

That same year, in MMM #51 DEC 1991, p 2, in the article “**Hybrid Rigid-inflatable Structures in Space,**” we suggested inflatable attachments to the Space Shuttle and to the Shuttle External Tank. This article is republished in MMM Classics #6 p. 2

[http://www.moonsociety.org/publications/mmm\\_classics/mmmc6\\_Jul2005.pdf](http://www.moonsociety.org/publications/mmm_classics/mmmc6_Jul2005.pdf)

Below are two of the design sketches included:



A Connestoga wagon inspired inflatable shelter unfolds from the Space Shuttle payload bay. The idea here was to send the Space Shuttle on a loop the Moon mission, with extra space provided for more comfortable lodging, recreation, whatever.

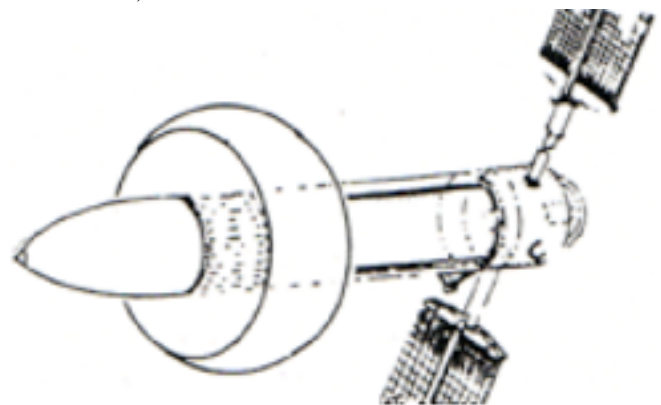

An external tank with an inflatable torus expanding out of the section joining the upper liquid oxygen tank with the lower liquid hydrogen tank, to create an artificial gravity environment through rotation.

Again, in this article we tried to suggest some directions hybrid rigid-inflatable architecture could take when applied to space vehicles, without any attempt to be complete much less exhaustive. Too many space enthusiasts are locked into traditional concepts, and it is regrettable that their imaginations are “caged in” by what has been “conventional” to date. “Conventional” should never be taken as “complete” or even as “the best.” We are never going to conquer space unless we unfetter our minds from the self-imposed bonds of previous thinkers!

Our purpose has thus been to stimulate fresh thought. Students should always question accepted assumptions. We would not be experiencing the present “wireless” revolution if someone had not been brave enough to do so! Almost all “breakthroughs” in science and technology begin with an act of intellectual courage, with the boldness to ask “what if?” And that is why we are publishing this article in MMM-India Quarterly. India’s students are eager to break past bonds.

**More Recent Suggestions**

In Moon Miners Manifesto - India Quarterly #6 Spring 2010, page 18, we reported a design for an inflatable addition to the top of an Orion crew capsule.





[http://www.moonsociety.org/india/mmm-india/m3india6\\_Spring2010.pdf](http://www.moonsociety.org/india/mmm-india/m3india6_Spring2010.pdf)

You could substitute any Crew Capsule design (Vostok, Shenzhou, India's orbital crew capsule now under design development) This concept could be used for a 2nd generation Space Adventures-Roscosmos "loop-the-Moon" tourist excursion vehicle's "habitat module" – a current artist illustration below



It also lends itself to space station architecture in which hybrid rigid-inflatable units are perhaps even more suitable for all the above-mentioned reasons than totally inflatable units.

To date, we have found no evidence that either the Russians or Chinese are exploring inflatable or hybrid rigid-inflatable architecture options. This leaves the field wide open for Commercial enterprises, and ISRO and its contractors to step in.

### More on Overlooked Inflatable Options:

See also the recent article in MMM # 237 August 2010 pages 4-5.

**“ Did the Bigelow Team make a major blunder in deciding that TranHab’s Rigid Inner Core was nonessential, and to develop only the Envelope? ”**

### The Point

The point is that we should not leave pursuit of inflatable architectures to Bigelow Aerospace alone. Hybrid-rigid inflatables offer the advantage of easier outfitting, and pre-attachment to hard hull modules, creating a wide-open field of “best of both worlds” solutions. ■

### M3IQ Challenge to Indian Student Teams

- Design an inflatable module to ride into space on top of ISRO’s manned capsule, outfitted as an exercise gym for individual gymnastics and 2-player sports, taking into account that while the gravity may be zero, mass and momentum are universal and unchanged. [The illustration at left can serve as a suggestion –but teams should feel free to come up with their own concepts for both exterior and interiors. The flexible pressure wall of your inflatable structure should be thick enough to act both as a shield against micrometeorite puncture and as thermal insulation. The Bigelow Aerospace inflatable wall is on the order of 30 cm thick

**Prizes:** Note: You will not be entering the NASA Competition described above as that is limited to US citizens. This challenge is open to Indian student teams and prizes , *not yet determined*, will be solicited from various organizations, space contractors, even ISRO. **To start this process**, the Lunar Reclamation Society (the Milwaukee, Wisconsin, USA chapter of the National Space Society and publishers of Moon Miners’ Manifesto, will contribute \$100 U.S. (4,454.62 INR) towards the 1<sup>st</sup> Prize plus a 3yr subscription to Moon Miners’ Manifesto (pdf file version).

**Judges:** The M3IQ Editorial Team (page 11)

**Acceptable Formats:**

**html, MS Word, Open Office, PDF**

**Deadline:** December 31·2011

**Electronic .doc and/or .pdf submission only:**

[mmm-india@moonsociety.org](mailto:mmm-india@moonsociety.org)



Bigelow Aerospace Inflated Genesis Module now in orbit

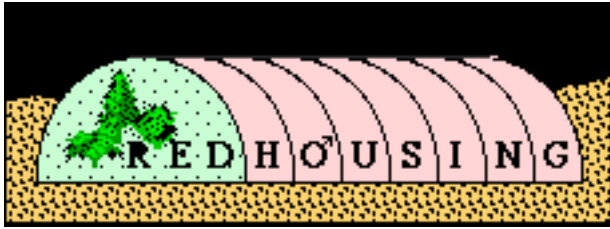

## Breeding Mars-hardy plants In Compressed Mars Air To meet Mars “half way”

By Peter Kokh

“REDHOUSING” MMM #93, March 1996, pp. 5-7.  
Reprinted in MMM Classic #10 pp. 25-27  
Freely downloadable pdf file from:  
[www.moonsociety.org/publications/mmm\\_classics/](http://www.moonsociety.org/publications/mmm_classics/)

### Foreword[ Romanticism dashed

I remember when Carl Sagan demonstrated that the seasonal markings on Mars were not due to spring waters flowing down the canals nurturing wide strips of vegetation to either side, but rather due to the redistribution of dust from darker areas on Mars via seasonal trade winds. And then came Mariner-9’s photos of a bleak, crater-pocked Martian surface, as apparently dead as the Moon. Before that we had been in a romantic delusion, understanding Mars as “a dying planet still holding on to life.”

There are many others who have seen their vision of Mars turned on its head, and who “in retaliation” as it were, have devised grandiose plans to “terraform” Mars, to make it more Earthlike and life-friendly. I have preferred to use the term “rejuvenate” or “rejuvenaissance” that is, making Mars more like it once was, but not necessarily like Earth is. But that too may be too romantic, as it may well turn out that Mars was never that much friendlier to life.

But the question remains. Can we tap Mars considerable water and carbon dioxide reserves locked up in its kilometers-thick polar caps to thicken the atmosphere and warm the planet to the point where water could flow on the surface without sublimating into space. Even if we could not transform the red planet to the point where people could go outdoors without spacesuits or breathing masks, could we actually “green” Mars, so that there would be green oases of life no matter how primitive? Even lichens and mosses would be a heart-warming sight – confirming that we were on a living planet, not just an awesome red rock.

### What can we do now?

Well, terraforming schemes are rather grandiose and something for the far future. What can we do now “to meet Mars half-way? To breed plants that could not survive on Mars as it is now, but might as the air began to thicken and the climate began to warm. Well, for one thing, we can create an environment in which “Mars Air” – CO<sub>2</sub> with some Nitrogen – is compressed by a factor of ten, still a factor of ten less dense than our own atmosphere. If we could slowly breed plants that could survive in such an atmosphere, even if their growth were slow, then, if ever we succeeded thickening Mars atmosphere to that point, those plants might successfully colonize areas of Mars surface.

### Redhousing

It’s a long shot, but will remain a dream unless we try. And this is a project we can do now, here on Earth. I call it “Redhousing.” Rather than repeat my previous article of fifteen years ago, you can download it. Here I would like to carry the idea further.



Oops! We forgot a color!

If ever we thickened and warmed the atmosphere to the point where it rained, the transition from “Red Mars” to “Green Mars” would be seriously delayed by an endless period of “Muddy Mars” unless- unless we began to “fix” the loose Martian soils with rooting plants. So development of such plants becomes a top priority if we are ever to see “Green Mars” and “Blue Mars.” This is homework we can do now, while we are still stuck on Earth, waiting for the development both of faster transportation systems, and biological life support systems independent of resupplies from Earth. It is two immature technologies that are holding us up, not just one! NASA has shown more interest in the transportation problem than in the life support problem. Fix one without the other and we are staying put on Mother Earth, continuing to daydream about Mars.

### Lichens and mosses? Or something else

Unfortunately, I can’t say that I have begun to experiment. I do not have a “green thumb!” In fact, even the artificial plants in my home shudder when I walk by, worried that I am going to “kill them too!” That is why I am writing this article, to encourage others who do have a “green thumb” to try experimenting.

But first we need a hardware person, someone to build our Redhouse chamber pressurized to 1/10<sup>th</sup> Earth normal, ten times Mars normal, and with the same atmospheric mix as Mars: 97% carbon dioxide, 3% nitrogen, both easy enough to find here on Earth. In the article referred to above, there are several options for building such a chamber and I do not pretend to know which one would be the best compromise between cost and ease of operation.

As a plant tender, you will have to wear an oxygen mask, as even this thickened Mars Air is not something one can breath. We just hope that plants can learn to do so! How long would it take? Perhaps many generations of plants, always selecting the hardiest, removing those that do less well. Perhaps we have to start with a thicker atmosphere and keep selecting the hardiest as we slowly reduce the pressure after each successful harvest.

Below are two schemes (of the four in the original article) for creating our “Redhouse.” What seems the simplest plan may prove the most difficult to maintain.

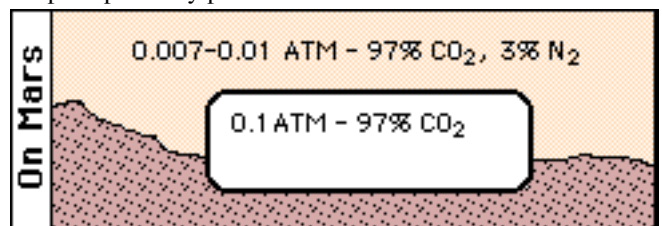

The problem here is that the oxygen rich outside air of Earth will try to pour into the Mars Air chamber where the air pressure is only a tenth that outside. One way to avoid such increasing contamination is to put the Redhouse under water.

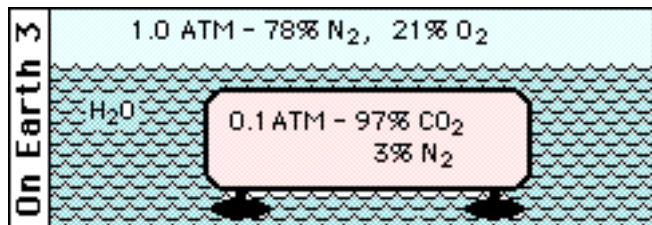

This chamber would have to be heavily weighted not to float to the top. In either case we will need an air-lock of some complexity and expense.

### All living things live in ecosystems

It is not enough to breed a “Mars Hardy” plant that could survive outdoors in a Mars Air that had been thickened by a factor of ten and warmed by some tens of degrees. What about microbial life to maintain soil in which the plant can root? While it is important to realize that in the end, we need to develop whole ecosystems for Mars, we should not be intimidated by this fact to the point that we do not attempt to breed “Mars Hardy” plants, as an encouraging first step. Rome was not built in a day, and neither will a Mars Hardy ecosystem be developed overnight. But the sooner we start the sooner those who follow us can advance towards such a goal.

### What plants to pick?

I mentioned lichens. There are many species of these plants in the arctic, and perhaps some in the Antarctic. We should try them all. But there may be other candidates, of which I am not aware. Again, not having “a green thumb” I am the last person to ask. What about plants that thrive at very high elevations, say in the high Himalayas? Are there any lichens or other plants on the ice-free Shirmacher Oases on which India’s Maitri Antarctic station sits. If not, could arctic species take hold there? Would transplantic such species be against the Antarctic Treaty? Again, we do not know. If so, it is a bad precedent. We must not only spread humans throughout the Solar System but complete Gaian ecosystems.

### Many options are worth trying

For interested Indians, there are many options: in the Himalayas, in Maitri, on any coast (or inland lake or pond underwater. Or just inside a lab. All Redhousing options should be tried if we want to ensure that at least one option leads somewhere.

One thing is for sure. If we do nothing but wait for NASA and other National Space Agencies to mount a first manned Mars mission, we will not be ready “to meet Mars half way” unless we have had some success, undoubtedly after many, many failures, with our Redhousing projects.

This is not the whole story, of course. Even if we succeed in breeding “Mars-hardy” plants, we still have to warm and thicken the atmosphere. And if our plants take to the new conditions, it may be only in some few locations.

But a good start is a good start! ▣

## Upcoming Conferences & Events

<http://www.spacecalendar.com/downrange/>

### INDIA

**Aug 8-9 – Galaxy Forum 2011** (Space Education), Bangalore

**Aug 19 – Committee on Space Research, Indian Space Research Organization, *Online*:** Webpage open for abstract submission for the ‘39th Scientific Assembly of Committee on Space Research (COSPAR)

### ELSEWHERE – a selection by the editor

**Jul 2 – International Lunar Observatory Association, Space Age Publishing Company, *Silicon Valley CA*:**

‘Galaxy Forum 2011: Galaxy Education and Galaxy Enterprise in the 21st Century.’

**Jul 3-8 – International Astrobiology Society, International Astronomical Union, *Montpellier, France*:** ‘IAS / IAU c51 (Bioastronomy) Joint International Conf’

**Jul 11-14 – International Academy of Astronautics, *Aosta, Italy*:** ‘7th Symposium on Realistic Advanced Scientific Space Missions: Missions to the Outer Solar System and Beyond.’

**July 21-24 – New Space Conference, Mountain View, CA**

**Jul 14-22 – Lunar and Planetary Institute, *Niigata, Japan*:** ‘Asteroids, Comets Meteors 2011.’

**Jul 26-29 – International Astronomical Union, *Chiang Mai, Thailand*:** ‘11th Asia-Pacific IAU Regional Meeting.’

**Aug 4-7 – The Mars Society, *Dallas TX*:** ‘14 Annual International Mars Society Convention

**Sep 12-16 – Lunar and Planetary Institute, *Fairbanks AK*:** ‘5th International Conference on Mars Polar Science and Exploration.’

**Sep 24-28 – International Academy of Astronautics, *Baia Chia, Sardinia*:** ‘4th IAA Symposium on Searching for Life Signatures.’

**Oct 3-7 International Astronautical Federation, *Cape Town, South Africa*:** ‘62nd Intern’l Astronautical Congress.’

### Pune entrepreneur's solar cap to keep you cool

[http://www.dnaindia.com/mumbai/report\\_pune-entrepreneur-s-solar-cap-to-keep-you-cool\\_1554149](http://www.dnaindia.com/mumbai/report_pune-entrepreneur-s-solar-cap-to-keep-you-cool_1554149)



## Student Space Organizations in India

### SEDS-India - <http://india.seds.org/>

(Students for the Exploration & Development of Space)

**National Headquarter - SEDS VIT,**

C/O , Dr. Geetha Manivasagam,  
Room No. 403 , CDMM Building ,  
VIT University,

VELLORE-632014, Tamil Nadu

Phone No. : +91-9952281231

Anmol Sharma (Director, Chapter Affairs)

**Current President:** Pranay Puchakayala

### SEDS-India Chapters:

<http://india.seds.org/CHAPTERS.HTML>

SEDS VIT (Vellore) (473 members)

SEDS Veltech (Chennai) (419 members)

SEDS Savitha (Chennai)

SEDS NITW (Warangal) (100 members)

SEDS GGITM (Bhopal) (89 members)

SEDS KCT (Coimbatore) (27 members)

SEDS ISM (Dhanbad)

SEDS NIT Trichy (Trichy) (17 members)

SEDS NIT (Nehru Institute of Tech, Coimbatore)

*See map on last page of this issue*

### SEDS-India Projects

<http://india.seds.org/projects.html>



## Help Wanted !

### MMM-India Quarterly Advisors, Liaisons, Contributors, Correspondents, Illustrators

If this publication is going to help spread the word about Space in India, among the public at large, and especially among the students and younger generation, it must become a truly Indian publication. We need people from many fields in India to join our team

If you think that you can add to the usefulness and vitality of this publication, in any of the ways listed above, or in fields we had not thought of, write us at:

[mmm-india@moonsociety.org](mailto:mmm-india@moonsociety.org)

[This email address goes to the whole editorial team]

Tell us about yourself; your interest in space, and how you think you can make this publication of real service in the education of the public in India, and in the education of young people on whom the future of India and the world will rest.

### Guidelines for Submissions

This publication is intended for wide public distribution to encourage support for space research and exploration and development.

It is not intended to be a scholarly review or a technical journal for professional distribution.

Submissions should be short, no more than a few thousand words. Longer pieces may be serialized

Editorials and Commentary, reports on actual developments and proposals, glimpses of life on the future space frontier, etc.

Articles about launch vehicles, launch facilities, space destinations such as Earth Orbit, The Moon, Mars, the asteroids, and beyond, challenges such as dealing with moon dust, radiation, reduced gravity, and more.

### Help Circulate MMM-India Quarterly

If you know someone who might enjoy reading this publication, send us their email address(es) so that they receive notice when a new issue is published.

Readers are encouraged to share and to distribute these issues widely, either as email attachments, or via the direct download address (for all issues):

<http://www.moonsociety.org/india/mmm-india/>

**MMM-India Quarterly will remain a free publication.** We will set up an online subscription service so that each issue is emailed to your email box directly, if you wish.

Printing this publication in the US would not be costly, but mailing it overseas to addresses in India would be.

If anyone in India wishes to become a Moon Society agent and publish and mail hardcopies of MMM-India Quarterly to addresses on a paid-subscription basis, please contact us at [mmm-india@moonsociety.org](mailto:mmm-india@moonsociety.org)

## MMM-India Quarterly #11 – July –Sept. 2011 Index - Table of Contents

- p. 2 About The Moon Society  
About “Moon Miners’ Manifesto”  
About “MMM-India Quarterly”
- p. 3 **INDIA-ISRO Space News:**  
Chandrayaan-2 Delay: CHANDRA photos
- p. 4 **Elsewhere in ASIA**  
China plans 1<sup>st</sup> docking; Robots to Moon in 2013
- p. 5 Japan: Ikaros Solar Sail, Akutsuki failure reports  
Russia’s all new Soyuz Capsule
- p. 6 Space News from Turkmenistan, Iran
- p. 7 **Elsewhere in the COMMONWEALTH**  
Space News from United Kingdom, Canada
- p. 8 Space News Australia, Malaysia, East Africa
- p. 9 **Elsewhere in the WORLD**  
Last of 3 US Shuttles is Retired: Commentary
- p. 10 Latin America: Mexico, Chile, Argentina, Brazil
- p. 11 M3IQ Editors; Book Review: Lunar Settlements
- p. 12 **Book Review:** The Diary of a Space Traveler
- p. 13 **Book Reviews:** What if Earth had 2 Moons?  
What if The Moon did not exist?
- p. 14 Great Browsing Links
- p. 15 Video Links; MMM Resources
- p. 16 M3IQ Photo Gallery  
**=== Major Articles ===**
- p. 17 Human Space Activity: The Spiritual Experience  
By Madhu Thangavelu
- p. 19 **Book:** The Overview Effect; Blue Marble Flag
- p. 20 The Case for Going to the Moon – Review  
and commentary by David Dunlop
- p. 22 Global View of Space Settlement Policy, Dunlop
- p. 25 Mapping the Era of Lunar Exploration, Dunlop
- p. 28 Microbial Life in Lake Untersee near Maitri, PK
- p. 29 Analog Research Updates, Peter Kokh
- p. 30 Exploring the Many Possibilities of Hybrid  
Rigid-Inflatable Architectures, Peter Kokh
- p. 34 Redhousing: Breeding “Mars-Hardy” Plants,  
Peter Kokh
- p. 35 Upcoming Conferences and Events

### If this publication has been forwarded to you by someone else,

and you would like to add your email address  
to our new-issue-ready announcement list,

Write [mmm-india@moonsociety.org](mailto:mmm-india@moonsociety.org)

Put “Subscribe” in the subject line of your email.

Include any comments you would like to make!

Feel free to send us email addresses of others,  
Individuals and/or organizations and/or lists.

“Always Bite off more than you (think you) can  
chew! (you may be surprised!)” - unknown

“We’re sorry, but the planet that you have dialed  
is not in service at this time, If you feel you have  
reached this recording in error, please hang up  
and try your call again later.”

Thanks to Ben Huset

“What is needed is not a one-time sprint to a  
nearby planet, but a slow, patient expansion away  
from Earth, a long-term program, perhaps taking  
a century to complete. - That would equip us not  
just for a single interplanetary joy ride but for  
the coordinated exploration of the deep solar  
system.”

- Isaac Asimov



Key: ■ ISRO Centres; ■ Moon Society; ■ SEDS; ■ NSS

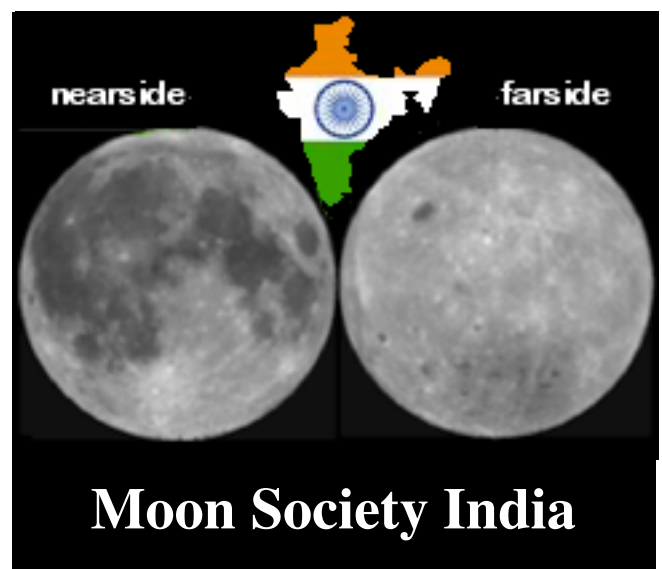

Engage! And Enjoy!